

A
B
C
D
E

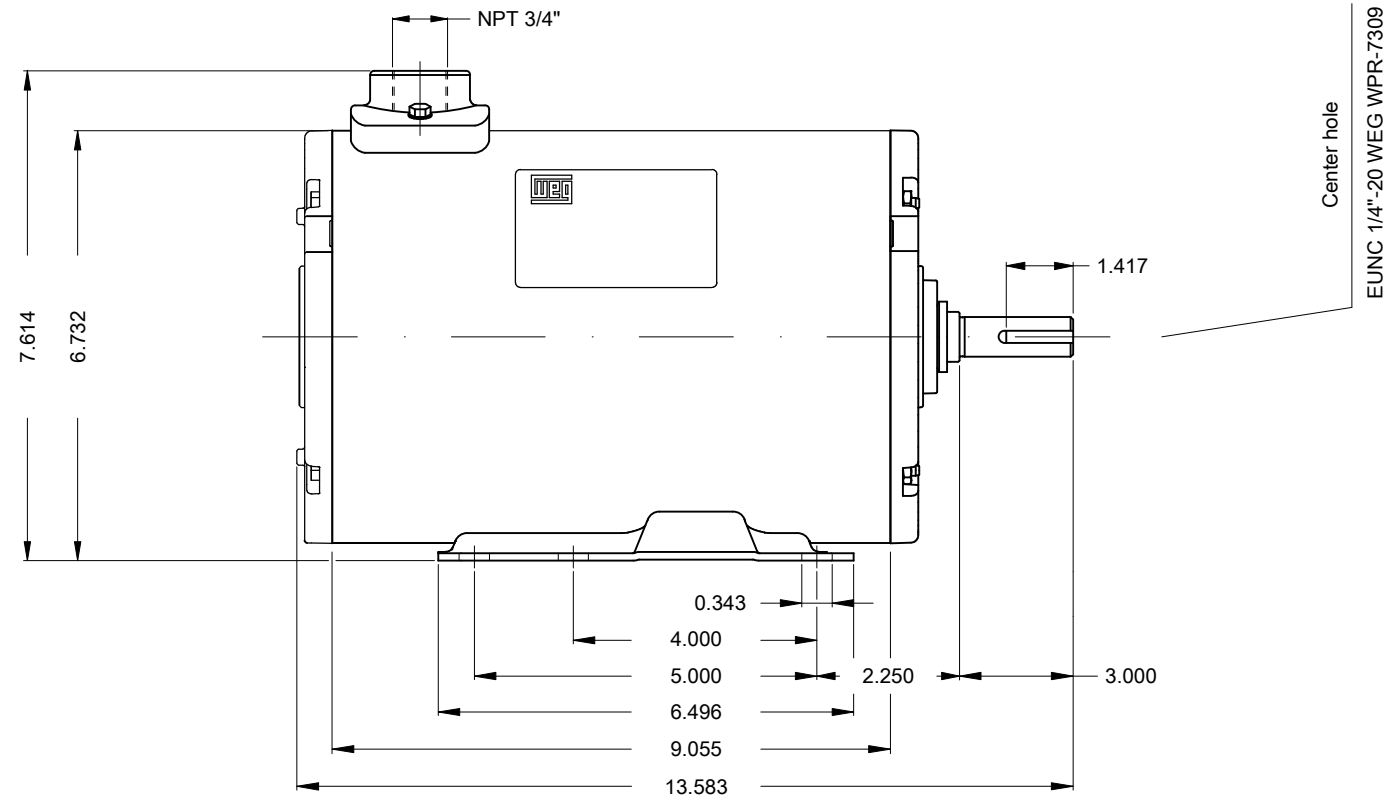
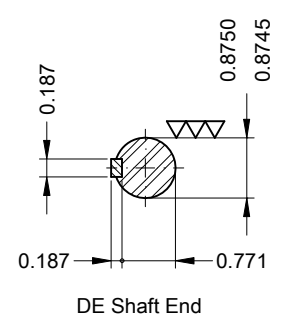
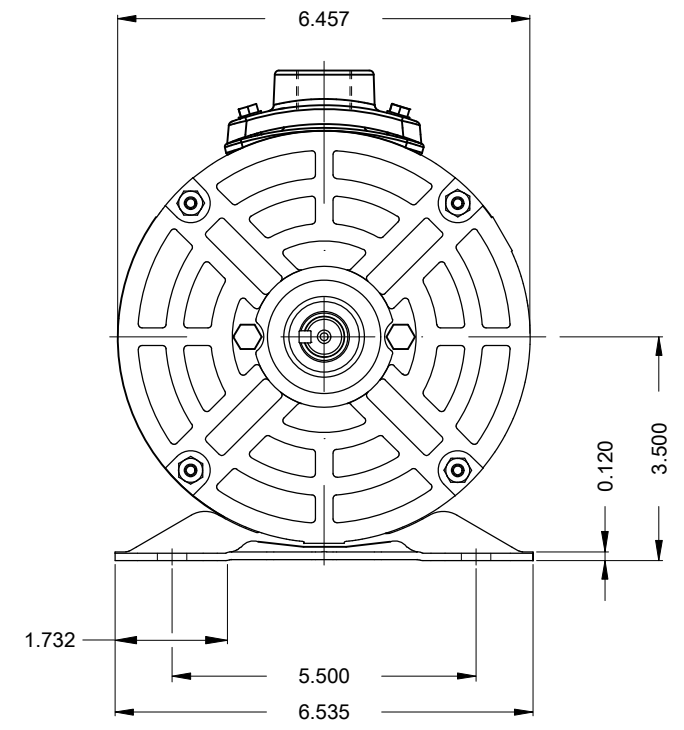
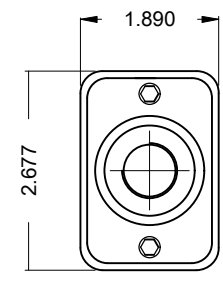

Reinforce the foot with 2 mig welding spots
 Color RAL 7031
 Painting plan 207N
 Mounting MARKET F-3/B3T
 Mounting B3T

						ALVAREZZ								00		
ECM	LOC	SUMMARY OF MODIFICATIONS				EXECUTED	CHECKED	RELEASED	DATE	VER						
EXECUTED	ALVAREZZ	THREE PH. MOTOR ROLLED STEEL GRAIN DRYER														
CHECKED		FRAME 143/5TZ IP55 TEAO														
RELEASED																
REL. DATE		WEG	HUEHUETOCA	[Ingenieria Motores Comerciales]			PREVIEW									
										WDD		00		SHEET 1 / 1		

3.0-4.5 HP 02 Poles 60 Hz

A

