

1 2 3 4 5 6

A  
B  
C  
D  
E

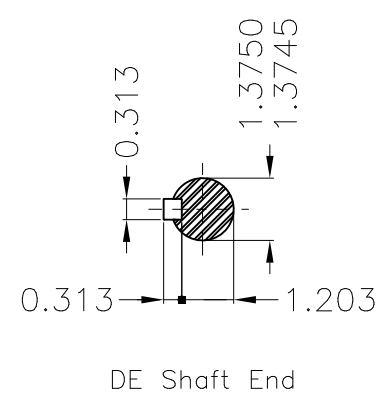
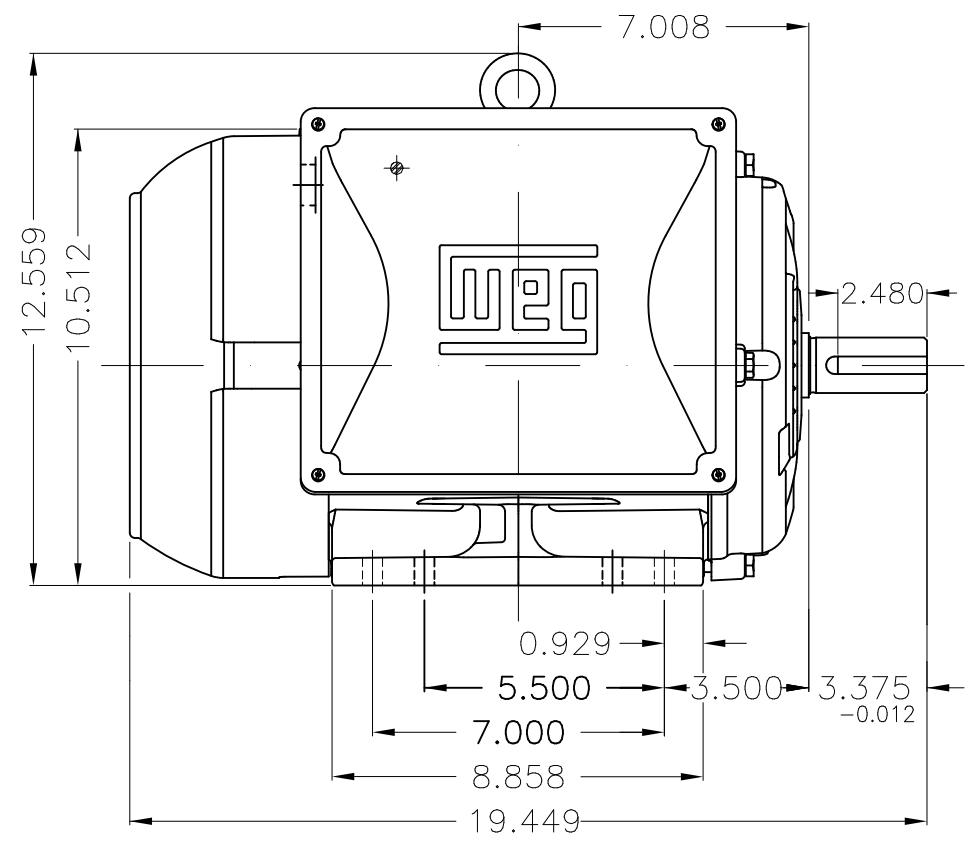
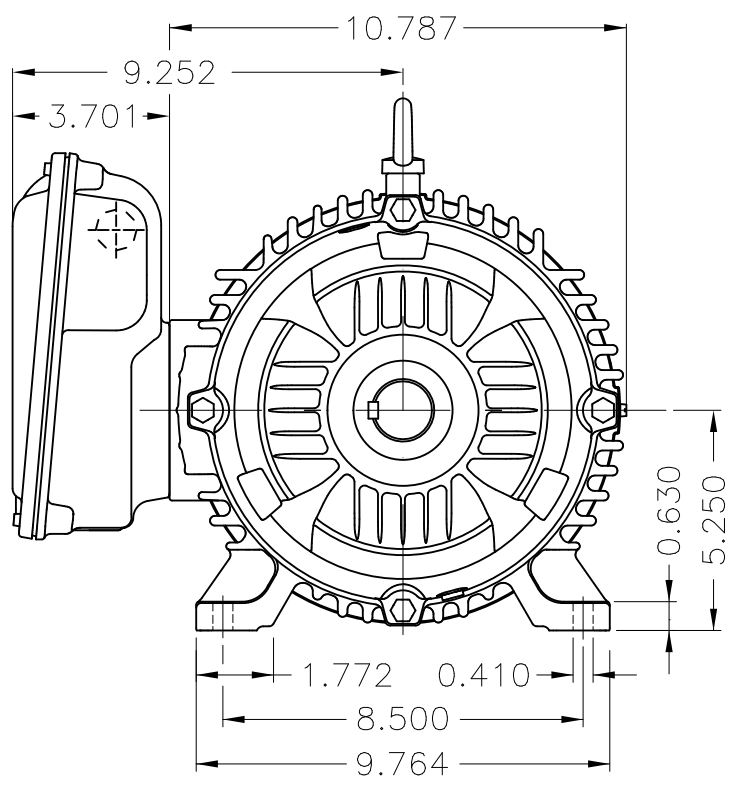
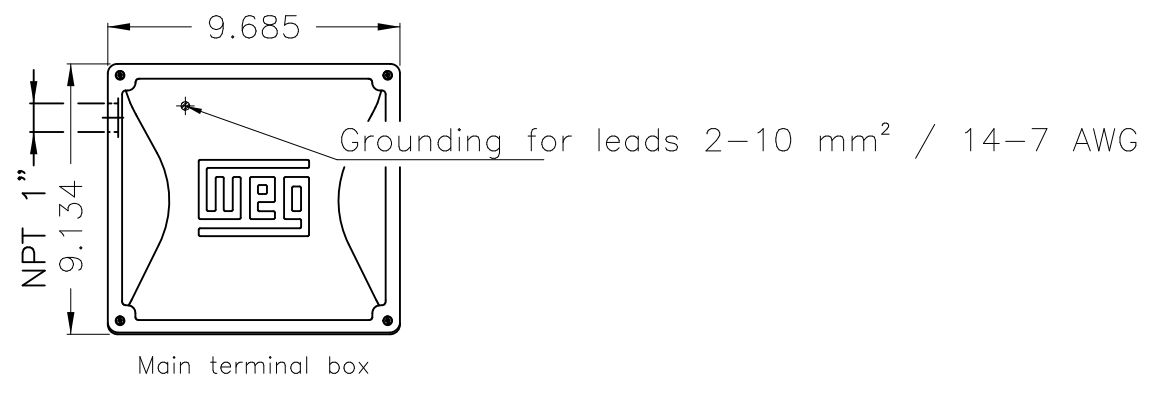

Color RAL 7022					
Mounting NEMA F-1					
Mounting B3R(D)					
				HYBRISUSER	00
ECM	LOC	SUMMARY OF MODIFICATIONS		EXECUTED	CHECKED
EXECUTED	HYBRISUSER	SINGLE PH. MOTOR W22			
CHECKED		FRAME 213/5T IP55 TEFC			
RELEASED					
REL. DATE	WMO	Jaragua do Sul	Product Engineering	PREVIEW	WDD 00
				SHEET	1 / 1

2 HP 06 Poles 60 Hz

A

