

EIXO/SHAFT	
PADRÃO/STANDARD	X
OPCIONAL/OPTIONAL	
ESPECIAL/SPECIAL	

Dimensões em polegada
Dimensions in inches

**CERTIFIED
WEG MOTORES**
Certified document.
Not subject to changes.

THIS IS AN UPDATED REVISION, THE
PREVIOUS ONE MUST BE DISREGARDED.

A
B
C
D
E

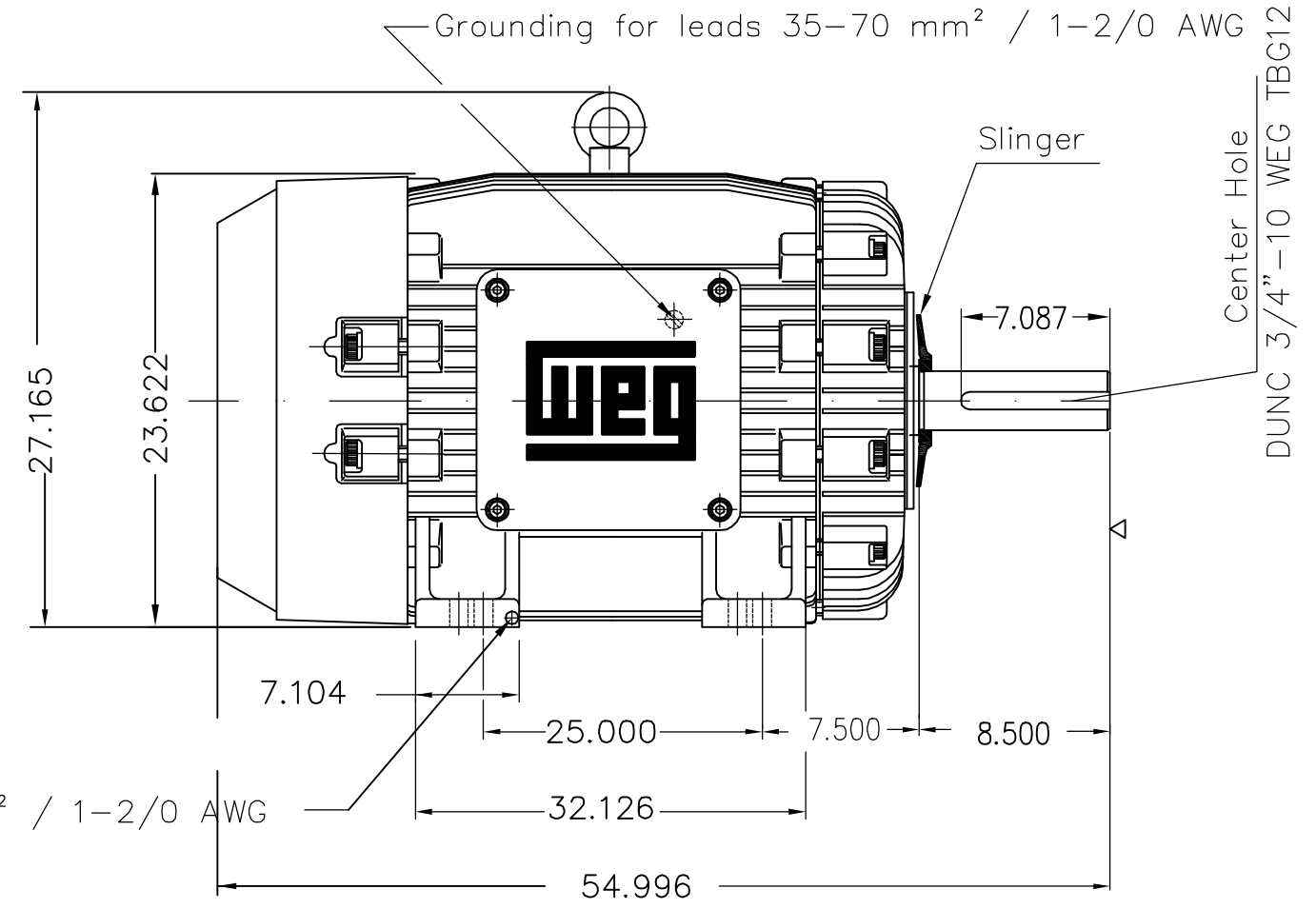
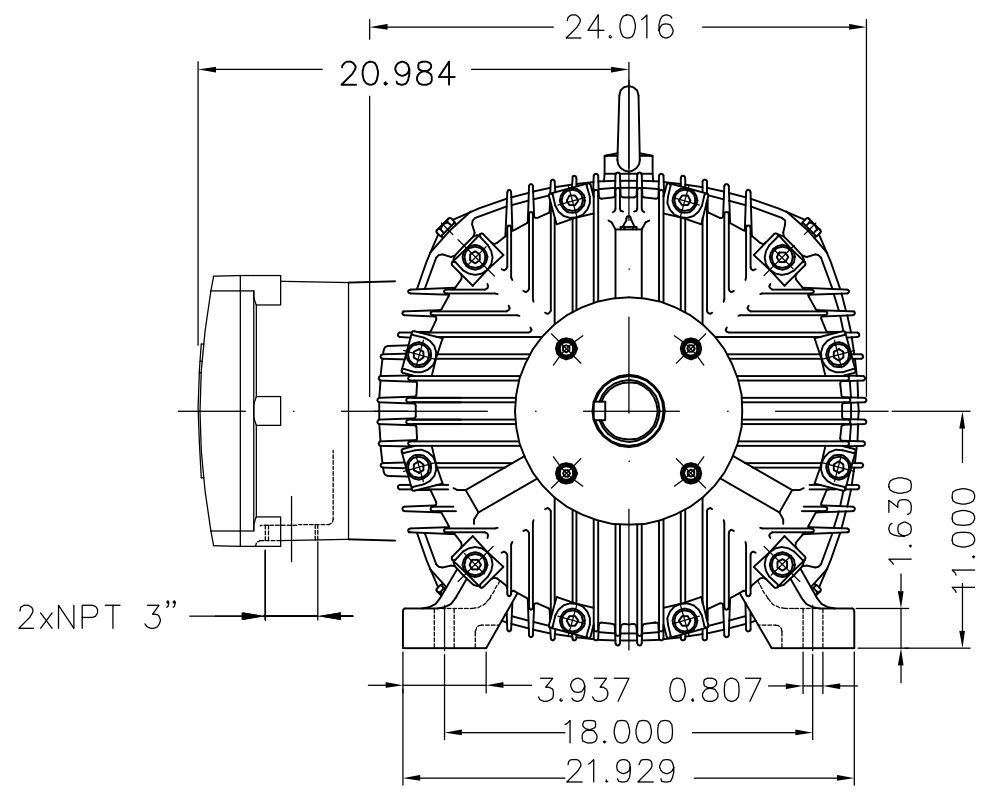

Grounding for leads 35-70 mm² / 1-2/0 AWG

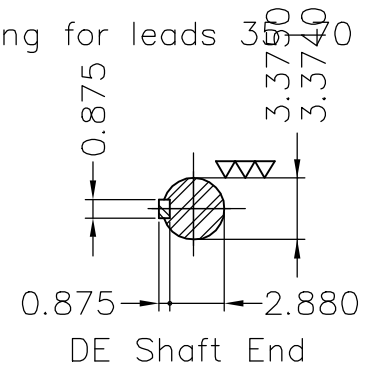

Rolamento dianteiro de rolos / DE roller bearing
Dispositivo de travamento de eixo / Shaft locking device
Slinger fornecido em avulso / Slinger ring supplied loose
Cor RAL 5009 / Color RAL 5009
Plano de pintura 202P / Painting plan 202P
Forma construtiva NEMA F-1 / Mounting NEMA F-1
Forma construtiva B3D / Mounting B3R(D)

V.J. PAMENSKY CANADA INC.

OV: 4491840

500001594952		ALTERADO CONF. CLAIM 415204042	RICLAV	DALTONR	DALTONR	27.05.2019	02
500001427824		REMOVED HIDDEN NOTE CODE 485	ERIC	MENSOR	MENSOR	13.03.2018	01
ECM	LOC	SUMMARY OF MODIFICATIONS	EXECUTED	CHECKED	RELEASED	DATE	VER
EXECUTED	GUSTAVOPT	THREE-PHASE EXPLOSION PROOF MOTOR FRAME 449T IP55 TEFC	10004902851				
CHECKED	PIRWUSER		000	02			
RELEASED	PIRWUSER						
REL DT	26.04.2017	WMO Jaragua do Sul	Product Engineering	SHEET	1 / 1		

300 HP 06 Poles 60Hz

A

UNCONTROLLED COPY
RELEASED
ZME A3