

EIXO/SHAFT	
PADRÃO/STANDARD	X
OPCIONAL/OPTIONAL	
ESPECIAL/SPECIAL	

Dimensões em polegada  
Dimensions in inches

**CERTIFIED WEG MOTORES**  
Certified document.  
Not subject to changes.

THIS IS AN UPDATED REVISION, THE PREVIOUS ONE MUST BE DISREGARDED.

A  
B  
C  
D  
E

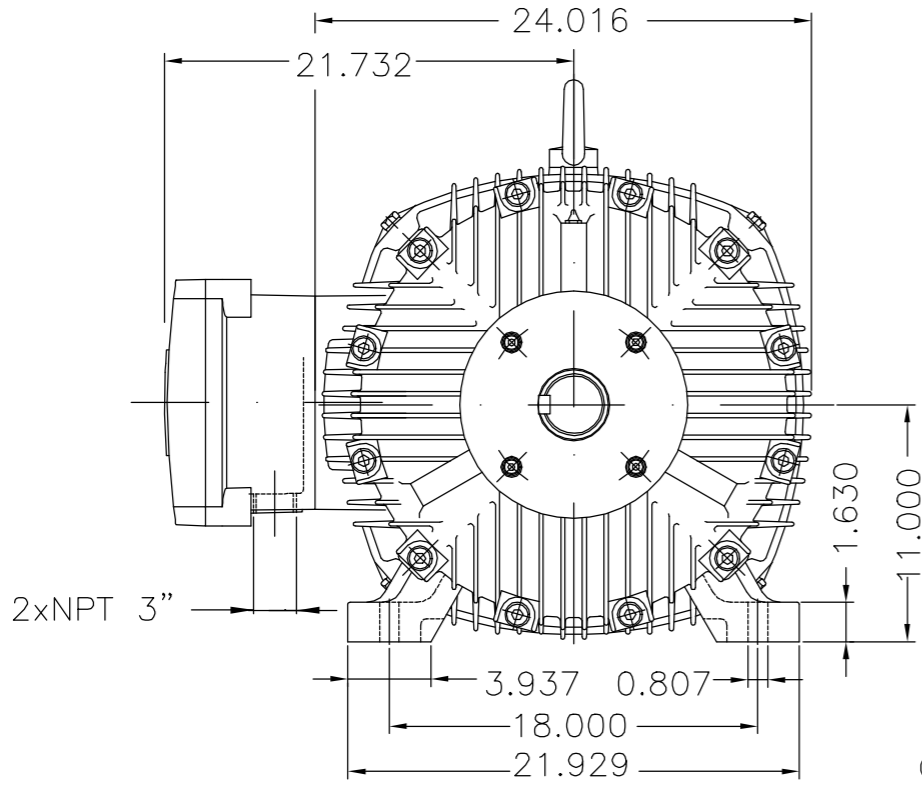

Grounding for leads 50-70 mm<sup>2</sup> / 1/0-2/0 AWG

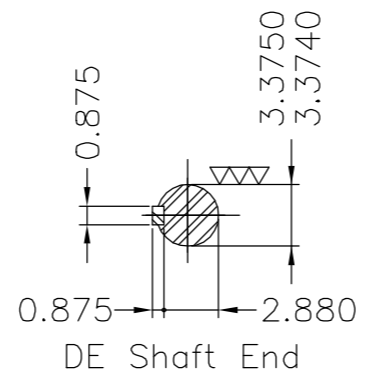
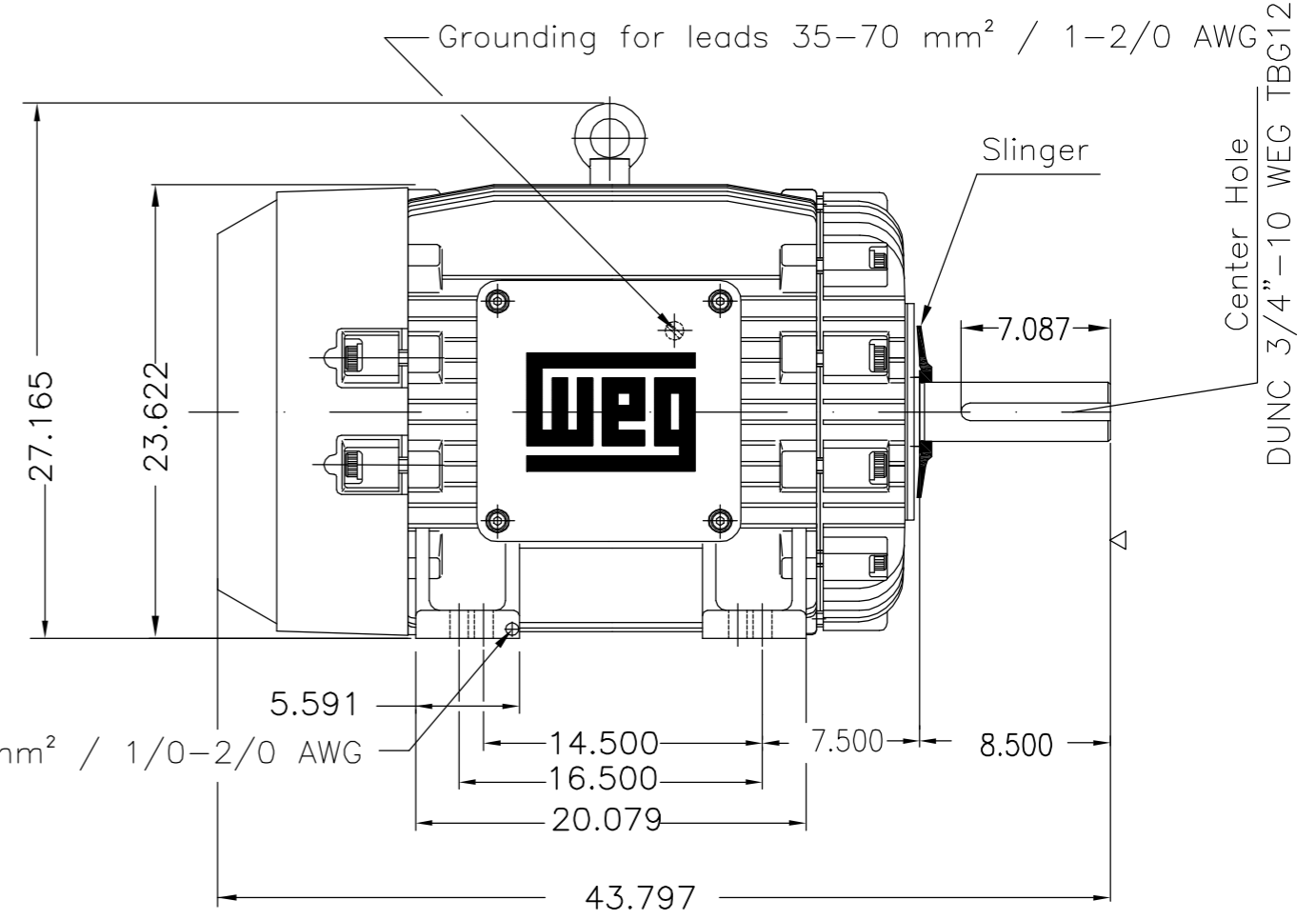

Rolamento dianteiro de rolos / DE roller bearing						
Dispositivo de travamento de eixo / Shaft locking device						
Slinger fornecido em avulso / Slinger ring supplied loose						
Cor RAL 5009 / Color RAL 5009						
Plano de pintura 202P / Painting plan 202P						
Forma construtiva NEMA F-1 / Mounting NEMA F-1						
Forma construtiva B3D / Mounting B3R(D)						
<b>V.J. PAMENSKY CANADA INC.</b>						

OV: 4330291

500001594952		ALTERADO CONF. CLAIM 415204042	RICLAV	DALTONR	DALTONR	27.05.2019	03
500001427824		REMOVED HIDDEN NOTE CODE 485	ERIC	MENSOR	MENSOR	13.03.2018	02
ECM	LOC	SUMMARY OF MODIFICATIONS	EXECUTED	CHECKED	RELEASED	DATE	VER
EXECUTED	FERNANDAM	THREE-PHASE EXPLOSION PROOF MOTOR FRAME 444/5T IP55 TEFC	10004621795		000   03		
CHECKED	PIRWUSER						
RELEASED	PIRWUSER						
REL DT	23.11.2016	WMO	Jaragua do Sul	Product Engineering	SHEET	01 / 01	

125 HP 06 Poles 60Hz



UNCONTROLLED COPY

RELEASED

ZME A3