

1 2 3 4 5 6

A
B
C
D
E

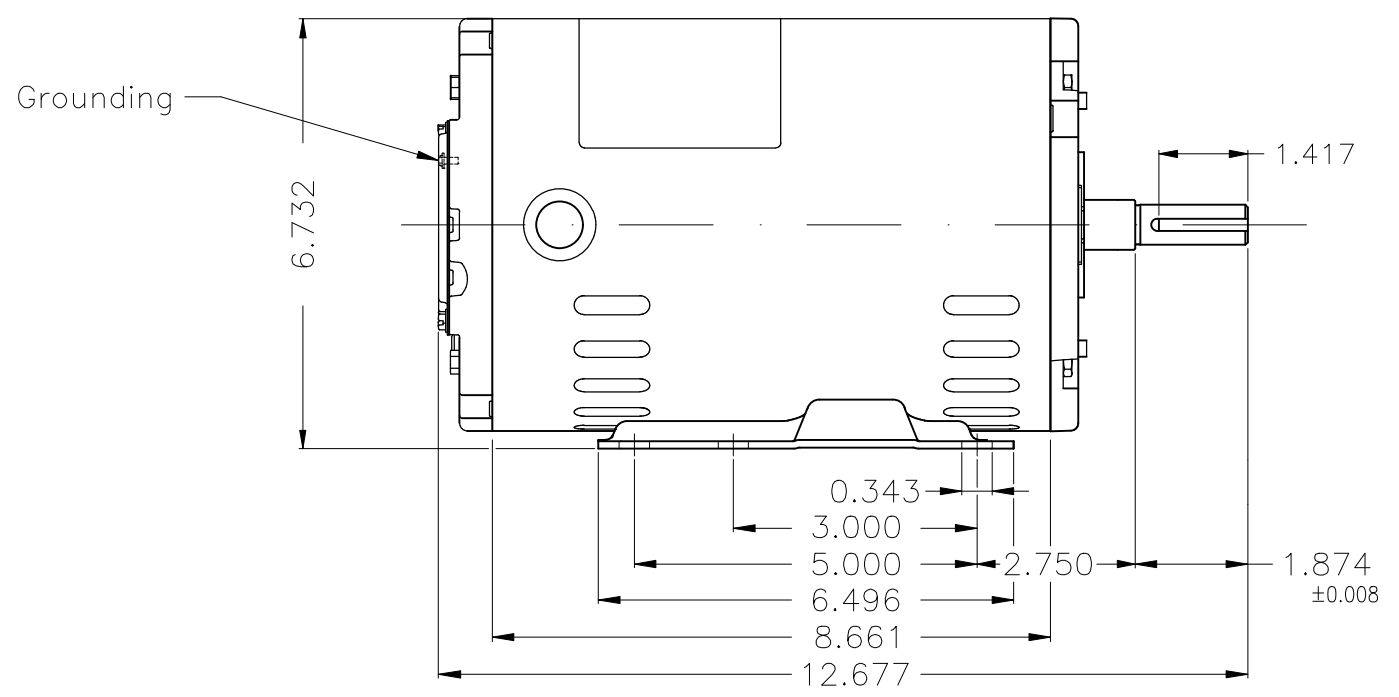
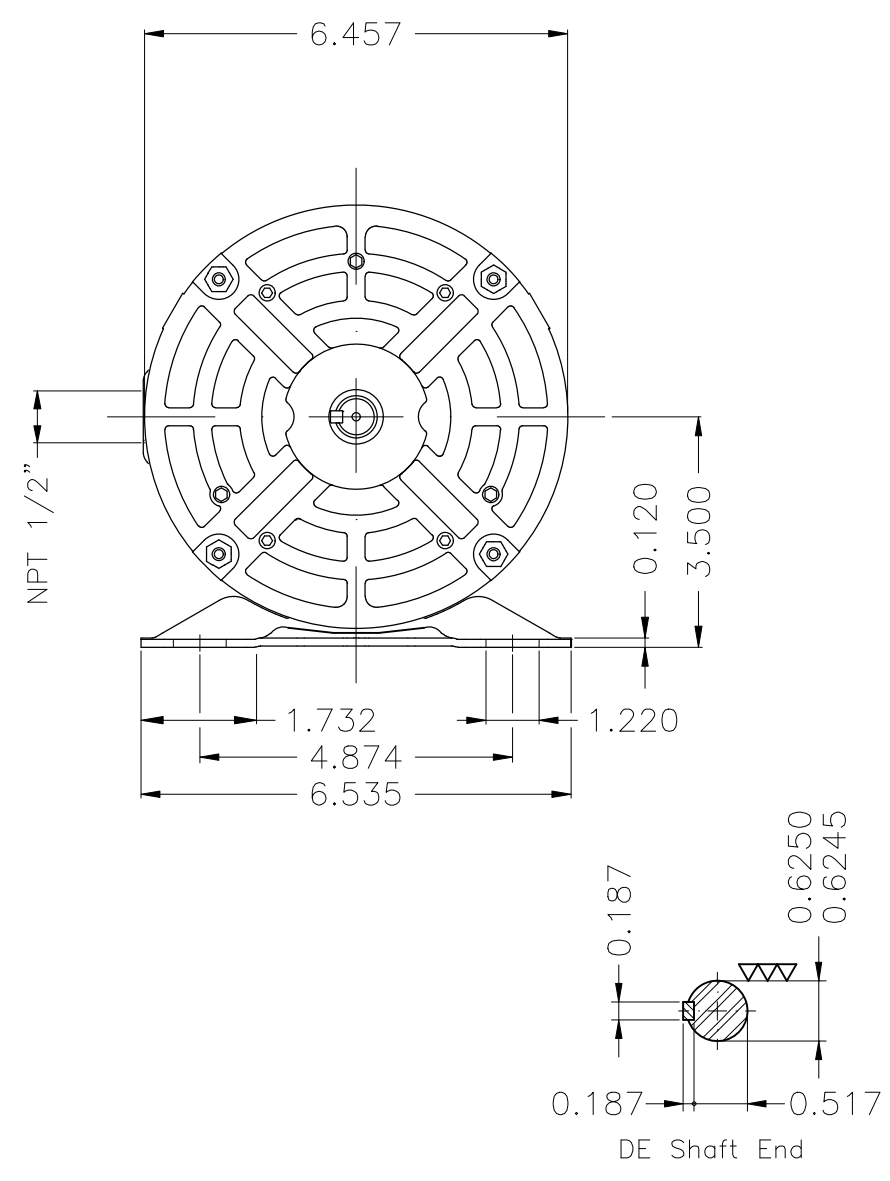

Color Munsell N 1 matte black						
Painting plan 207N						
Mounting F-1/B3R(D)						
					HYBRISUSER	00
ECM	LOC	SUMMARY OF MODIFICATIONS		EXECUTED	CHECKED	RELEASED
EXECUTED	HYBRISUSER	THREE PH. MOTOR ROLLED STEEL PREM. EFF.			PREVIEW	
CHECKED		FRAME 56H IP21 ODP			WDD	00
RELEASED						
REL. DATE		WMO	Jaragua do Sul	Product Engineering	SHEET	1 / 1

2 HP 04 Poles 60 Hz

A



Dimensions in inches XME A3