

DATA SHEET



Three Phase Induction Motor - Squirrel Cage

Customer :						
Product line		: W22 NEMA Premium Efficiency Three-Phase		Product code :		11535528
Frame	:	213/5TC		Locked rotor time	:	27s (cold) 15s (hot)
Output	:	10 HP (7.5 kW)		Temperature rise	:	80 K
Frequency	:	60 Hz		Duty cycle	:	Cont.(S1)
Rated voltage	:	575 V		Ambient temperature	:	-20°C to +40°C
Poles	:	2		Altitude	:	1000 m.a.s.l.
Rated current	:	9.28 A		Protection degree	:	IP55
	:	7.2x(Code H)		Cooling method	:	IC411 - TEFC
Rated speed	:	3530 rpm		Mounting	:	F-1
Rated torque	:	2.06 kgfm		Rotation ¹	:	Both (CW and CCW)
Insulation class	:	F		Noise level ²	:	68.0 dB(A)
Service factor	:	1.25		Starting method	:	Direct On Line
Moment of inertia (J)	:	0.0268 kgm ²		Approx. weight ³	:	78.3 kg
Design	:	B				
Output	50%	75%	100%	Foundation loads		
Efficiency (%)	89.5	90.2	90.2	Max. traction : 71 kgf		
Power Factor	0.79	0.87	0.90	Max. compression : 149 kgf		
Losses at normative operating points (speed;torque), in percentage of rated output power						
P1 (0,9;1,0)	P2 (0,5;1,0)	P3 (0,25;1,0)	P4 (0,9;0,5)	P5 (0,5;0,5)	P6 (0,5;0,25)	P7 (0,25;0,25)
10.6	8.9	8.2	5.1	3.3	2.0	1.3
		<u>Drive end</u>		<u>Non drive end</u>		
Bearing type	:	6308 ZZ		6207 ZZ		
Sealing	:	V'Ring		V'Ring		
Lubrication interval	:	-		-		
Lubricant amount	:	-		-		
Lubricant type	:		00088			
Notes						
This revision replaces and cancel the previous one, which must be eliminated. (1) Looking the motor from the shaft end. (2) Measured at 1m and with tolerance of +3dB(A). (3) Approximate weight subject to changes after manufacturing process. (4) At 100% of full load.				These are average values based on tests with sinusoidal power supply, subject to the tolerances stipulated in NEMA MG-1.		
Rev.	Changes Summary			Performed	Checked	Date
Performed by						
Checked by					Page	Revision
Date	07/04/2026				1 / 2	

LOAD PERFORMANCE CURVE

Three Phase Induction Motor - Squirrel Cage



Customer : _____

Product line : W22 NEMA Premium Efficiency Three-Phase Product code : 11535528

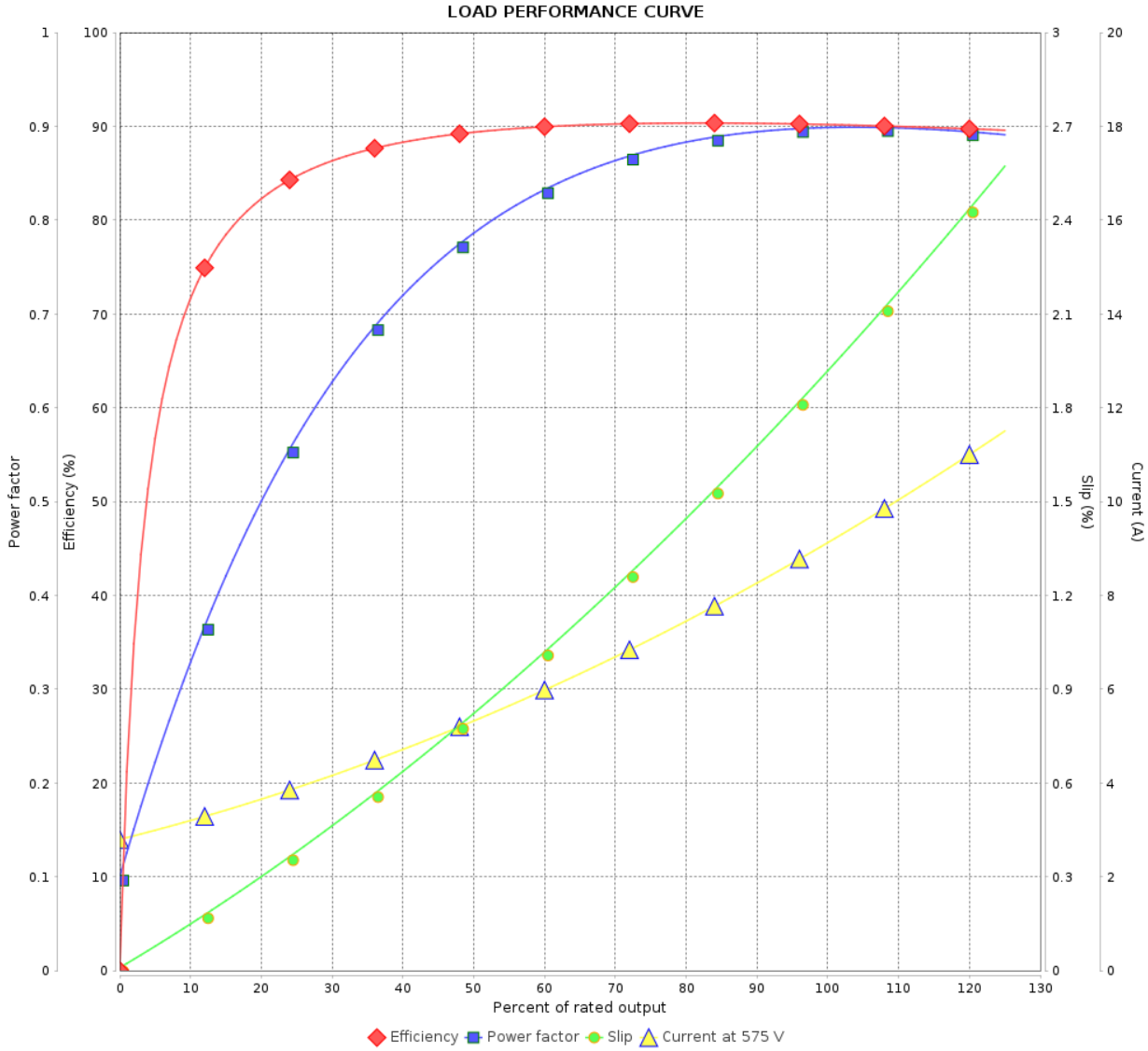

Rev.	Changes Summary	Performed	Checked	Date
Performed by		Page		Revision
Checked by		2 / 2		
Date		07/04/2026		

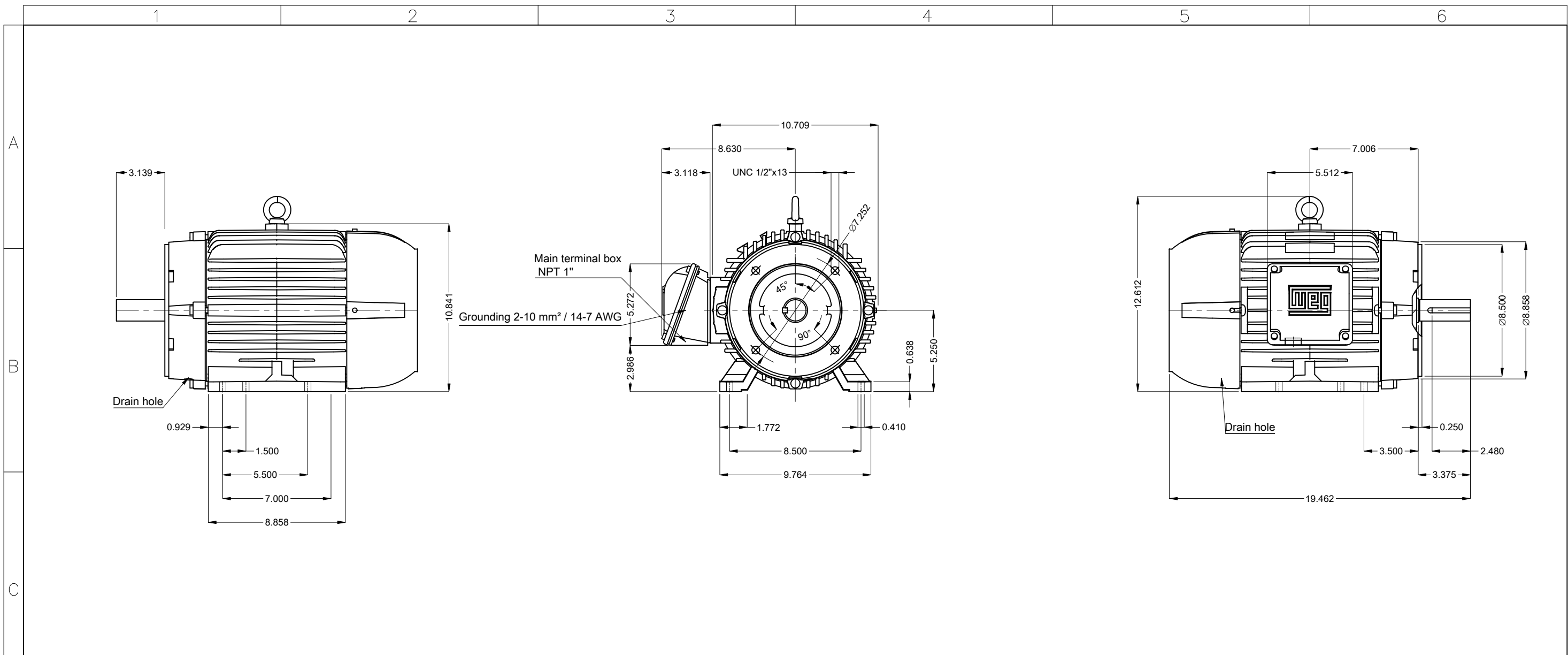

Color RAL 5009
 Painting plan 207A
 Mounting B34D

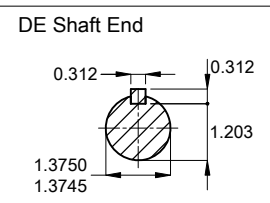

10 HP 02 Poles 60 Hz										A	
Scale										2 : 13	
HYBRISUSER										00	
ECM	LOC	SUMMARY OF MODIFICATIONS					EXECUTED	CHECKED	RELEASED	DATE	VER
EXECUTED	HYBRISUSER	THREE PH. MOTOR W22 NEMA PREM. EFF.						PREVIEW			
CHECKED		FRAME 213/5TC IP55 TEFC						WDD	00		
RELEASED								SHEET	1 / 1		
REL. DATE											