

DATA SHEET

Single Phase Induction Motor - Squirrel Cage



Customer	:			
Product line	: Single-Phase	Product code : 13965357		
Frame	: 56	Cooling method : IC01 - ODP		
Insulation class	: F	Mounting : F-1		
Duty cycle	: Cont.(S1)	Rotation ¹ : Both (CW and CCW)		
Ambient temperature	: -20°C to +40°C	Starting method : Direct On Line		
Altitude	: 1000 m.a.s.l.	Approx. weight ³ : 19.8 kg		
Design	: L	Moment of inertia (J) : 0.0057 kgm ²		
Output [HP]		1.5		
Poles		4		
Frequency [Hz]		60		
Rated voltage [V]		115/208-230		
Rated current [A]		19.0/10.5-9.49		
L. R. Amperes [A]		131/72.5-65.5		
LRC [A]		6.9x(Code J)		
No load current [A]		15.4/6.64-7.70		
Rated speed [RPM]		1745		
Slip [%]		3.06		
Rated torque [kgfm]		0.624		
Locked rotor torque [%]		270		
Breakdown torque [%]		270		
Service factor				
Temperature rise		80 K		
Locked rotor time		12s (cold) 7s (hot)		
Noise level ²		52.0 dB(A)		
Efficiency (%)	25%			
	50%	66.0		
	75%	72.0		
	100%	73.0		
Power Factor	25%			
	50%	0.48		
	75%	0.60		
	100%	0.69		
Bearing type	: <u>Drive end</u> 6204 ZZ <u>Non drive end</u> 6202 ZZ	Foundation loads		
Sealing	: Without Bearing Seal Without Bearing Seal	Max. traction : 43 kgf		
Lubrication interval	: - -	Max. compression : 63 kgf		
Lubricant amount	: - -			
Lubricant type	: Mobil Polyrex EM			
Notes				
<p>This revision replaces and cancel the previous one, which must be eliminated.</p> <p>(1) Looking the motor from the shaft end.</p> <p>(2) Measured at 1m and with tolerance of +3dB(A).</p> <p>(3) Approximate weight subject to changes after manufacturing process.</p> <p>(4) At 100% of full load.</p>		<p>These are average values based on tests with sinusoidal power supply, subject to the tolerances stipulated in NEMA MG-1.</p>		
Rev.	Changes Summary	Performed	Checked	Date
Performed by				
Checked by			Page	Revision
Date	11/05/2022		1 / 2	

LOAD PERFORMANCE CURVE

Single Phase Induction Motor - Squirrel Cage



Customer :

Product line : Single-Phase

Product code : 13965357

LOAD PERFORMANCE CURVE

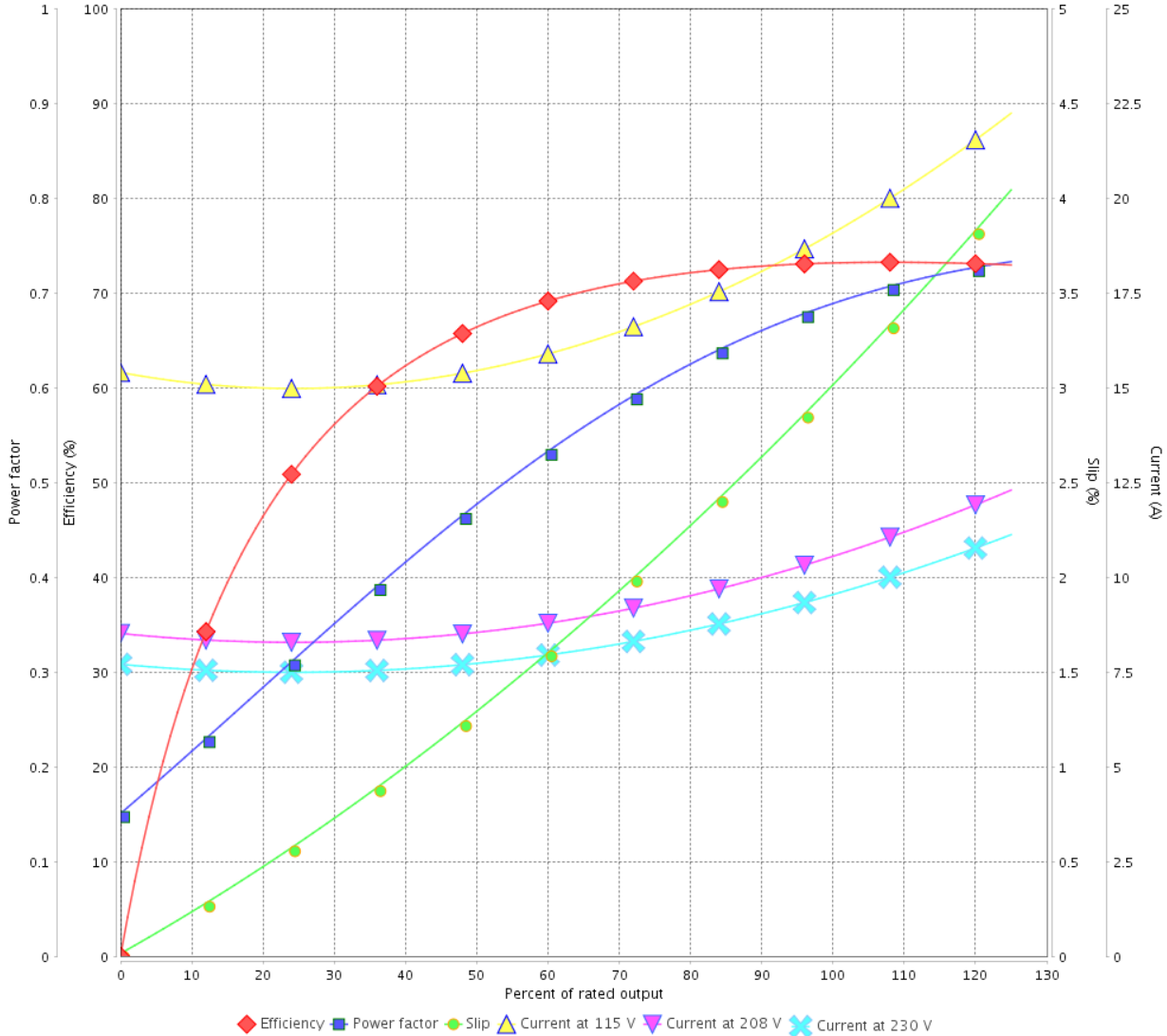

Performance : 115/208-230 V 60 Hz 4P

Rated current : 19.0/10.5-9.49 A
 LRC : 6.9
 Rated torque : 0.624 kgfm
 Locked rotor torque : 270 %
 Breakdown torque : 270 %
 Rated speed : 1745 rpm

Moment of inertia (J) : 0.0057 kgm²
 Duty cycle : Cont.(S1)
 Insulation class : F
 Service factor :
 Temperature rise : 80 K
 Design : L

Rev.	Changes Summary	Performed	Checked	Date
Performed by			Page 2 / 2	Revision
Checked by				
Date	11/05/2022			

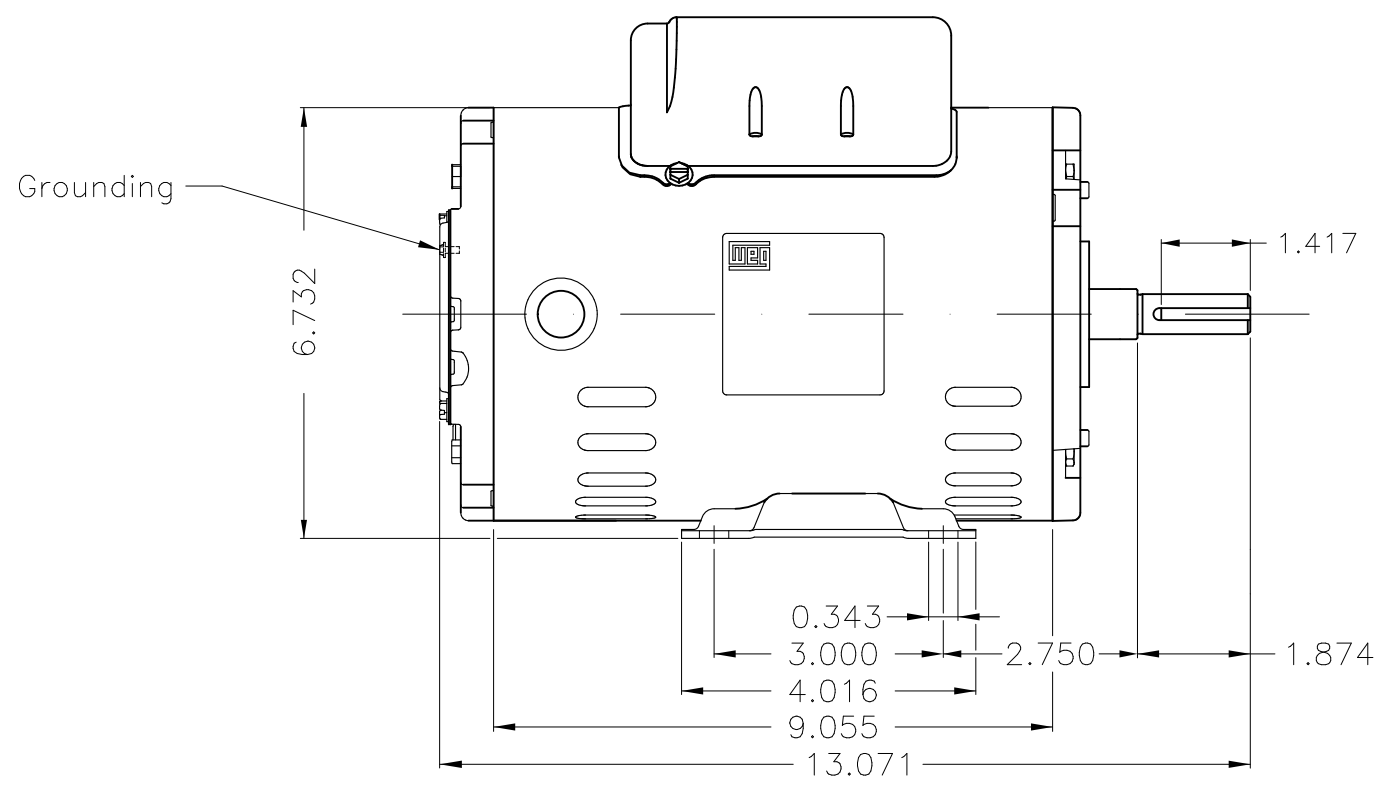
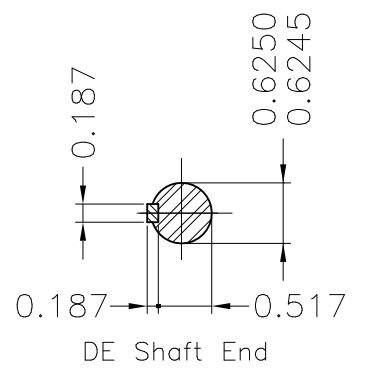
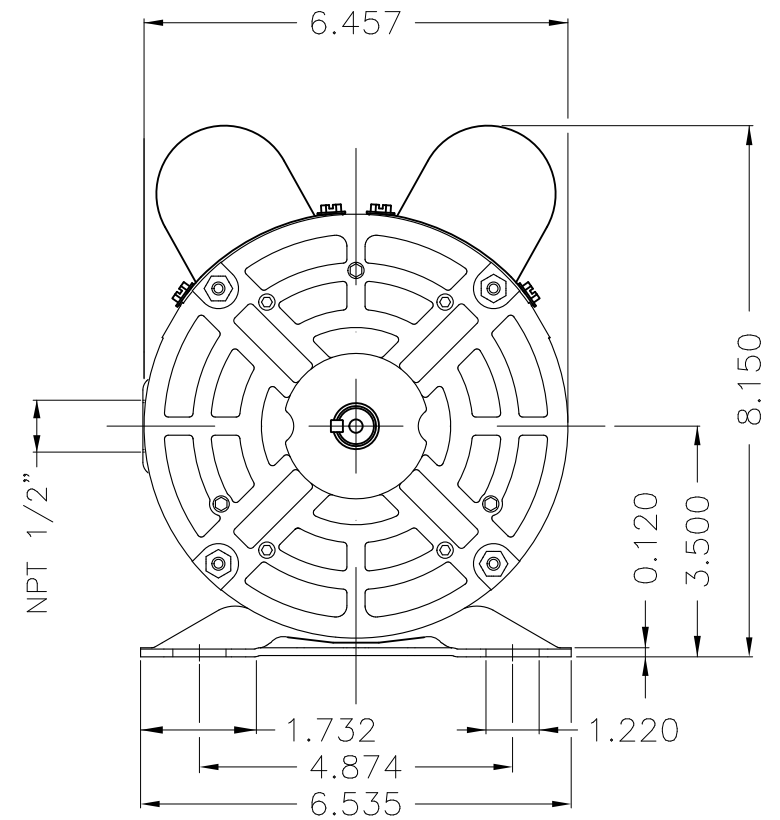

Color RAL 7022					
Painting plan 207N					
Mounting F-1/B3R(D)					
				HYBRISUSER	00
ECM	LOC	SUMMARY OF MODIFICATIONS	EXECUTED	CHECKED	RELEASED
EXECUTED	HYBRISUSER	SINGLE PH. MOTOR ROLLED STEEL FRAME 56 IP21 ODP		PREVIEW	
CHECKED				WDD	00
RELEASED				SHEET	1 / 1
REL. DATE		WMO Jaragua do Sul	Product Engineering		

1.5 HP 04 Poles 60 Hz

A