

DATA SHEET

Single Phase Induction Motor - Squirrel Cage



Customer	:			
Product line	: Jet Pump - C type Single-Phase	Product code : 13917953		
Frame	: 56C	Cooling method : IC411 - TEFC		
Insulation class	: F	Mounting : F-1		
Duty cycle	: Cont.(S1)	Rotation ¹ : CCW		
Ambient temperature	: -20°C to +40°C	Starting method : Direct On Line		
Altitude	: 1000 m.a.s.l.	Approx. weight ³ : 21.7 kg		
Protection degree	: IP55	Moment of inertia (J) : 0.0040 kgm ²		
Design	: L			
Output [HP]		3		
Poles		2		
Frequency [Hz]		60		
Rated voltage [V]		230		
Rated current [A]		12.7		
L. R. Amperes [A]		102		
LRC [A]		8.0x(Code J)		
No load current [A]		4.00		
Rated speed [RPM]		3490		
Slip [%]		3.06		
Rated torque [kgfm]		0.624		
Locked rotor torque [%]		210		
Breakdown torque [%]		250		
Service factor		1.15		
Temperature rise		80 K		
Locked rotor time		10s (cold) 6s (hot)		
Noise level ²		68.0 dB(A)		
Efficiency (%)	25%			
	50%	76.0		
	75%	79.0		
	100%	80.0		
Power Factor	25%			
	50%	0.86		
	75%	0.92		
	100%	0.94		
Bearing type	: <u>Drive end</u> 6203 2RS <u>Non drive end</u> 6202 2RS	Foundation loads		
Sealing	: V'Ring V'Ring	Max. traction : 38 kgf		
Lubrication interval	: - -	Max. compression : 60 kgf		
Lubricant amount	: - -			
Lubricant type	: Mobil Polyrex EM			
Notes				
<p>This revision replaces and cancel the previous one, which must be eliminated.</p> <p>(1) Looking the motor from the shaft end.</p> <p>(2) Measured at 1m and with tolerance of +3dB(A).</p> <p>(3) Approximate weight subject to changes after manufacturing process.</p> <p>(4) At 100% of full load.</p>		<p>These are average values based on tests with sinusoidal power supply, subject to the tolerances stipulated in NEMA MG-1.</p>		
Rev.	Changes Summary	Performed	Checked	Date
Performed by				
Checked by			Page	Revision
Date	11/05/2022		1 / 2	

LOAD PERFORMANCE CURVE

Single Phase Induction Motor - Squirrel Cage



Customer :

Product line : Jet Pump - C type Single-Phase Product code : 13917953

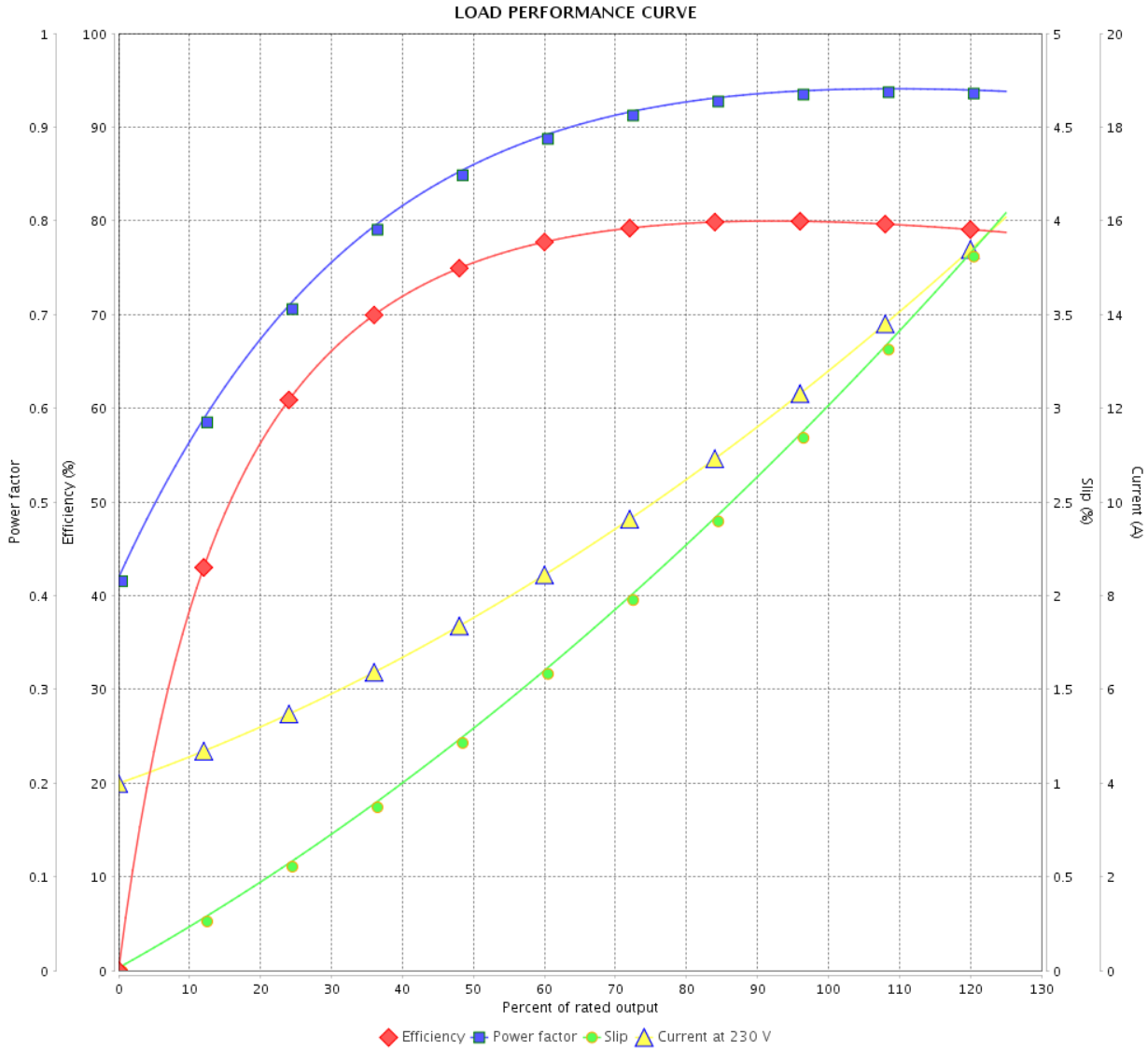

Performance : 230 V 60 Hz 2P

Rated current	: 12.7 A	Moment of inertia (J)	: 0.0040 kgm ²
LRC	: 8.0	Duty cycle	: Cont.(S1)
Rated torque	: 0.624 kgfm	Insulation class	: F
Locked rotor torque	: 210 %	Service factor	: 1.15
Breakdown torque	: 250 %	Temperature rise	: 80 K
Rated speed	: 3490 rpm	Design	: L

Rev.	Changes Summary	Performed	Checked	Date
Performed by			Page 2 / 2	Revision
Checked by				
Date	11/05/2022			

1 2 3 4 5 6

A

B

C

D

E

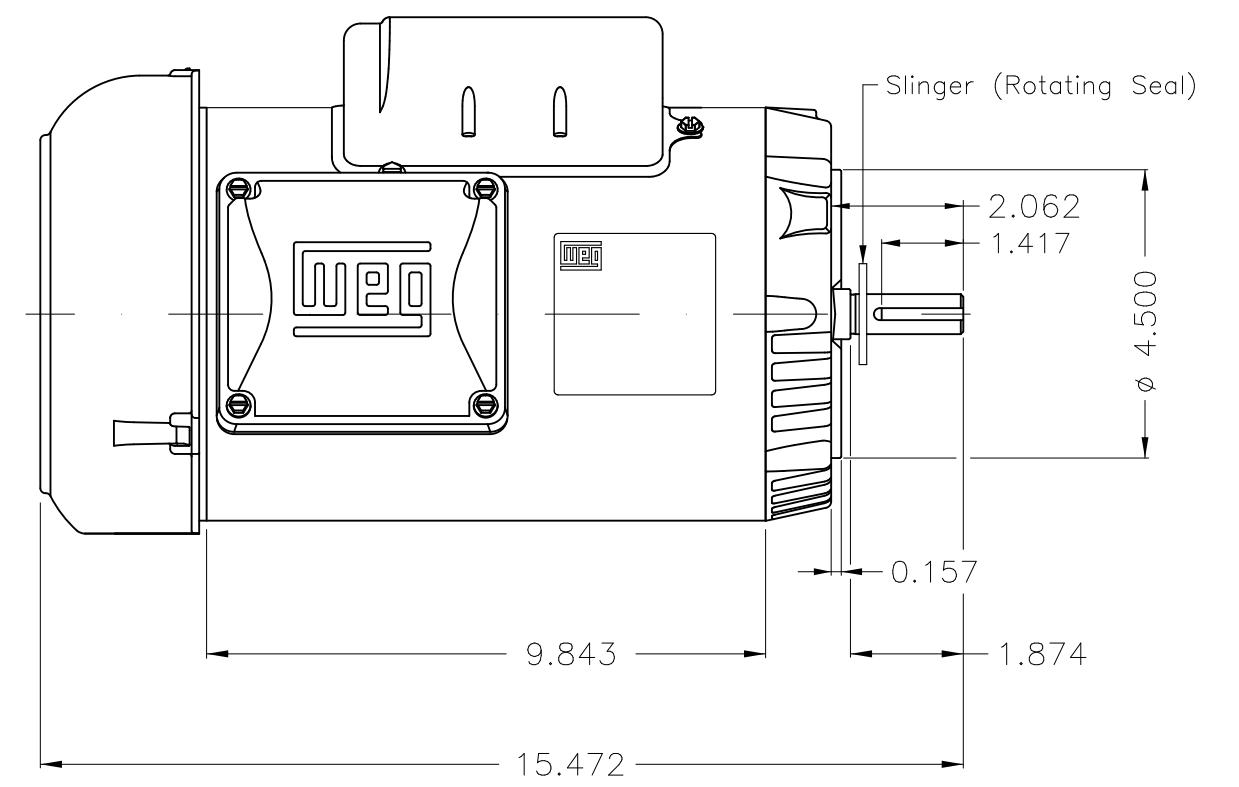
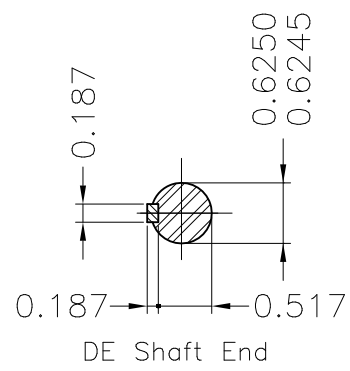
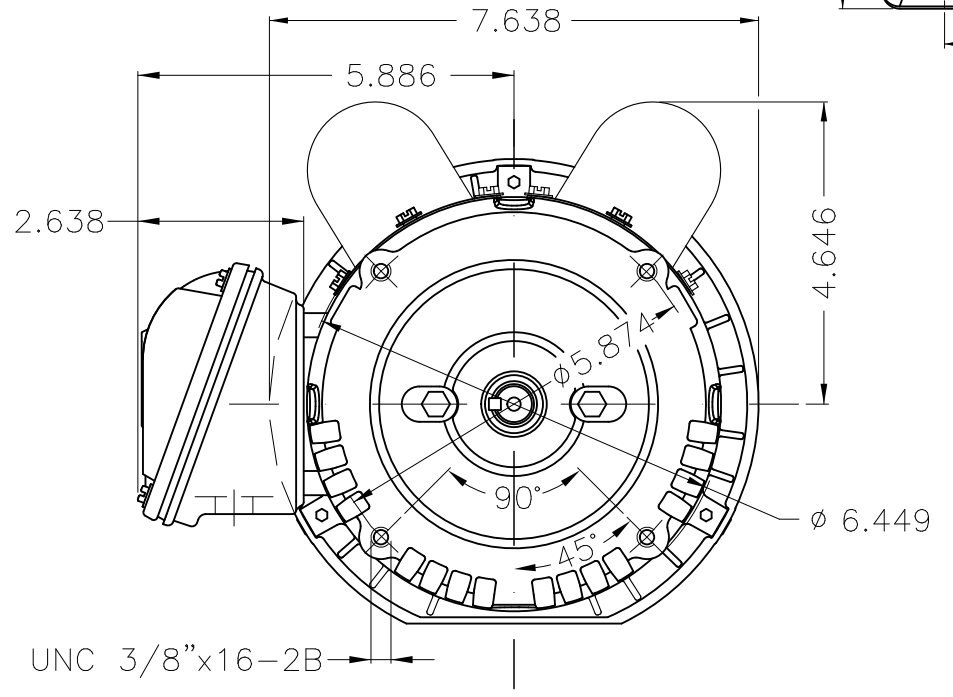
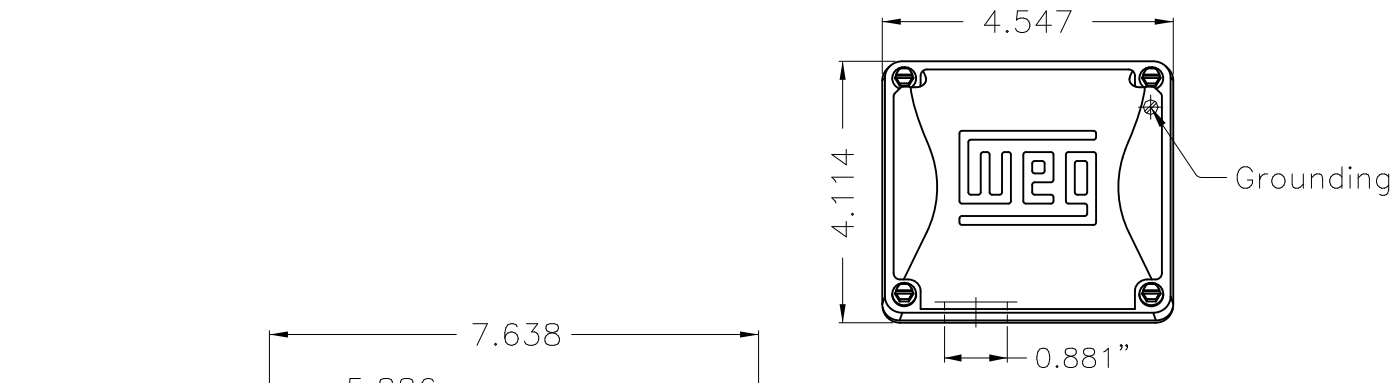

Color Munsell N 1 matte black						
Painting plan 207N						
Mounting F-1/B14R(D)						
					HYBRISUSER	00
ECM	LOC	SUMMARY OF MODIFICATIONS		EXECUTED	CHECKED	RELEASED
EXECUTED	HYBRISUSER	SINGLE PH. MOTOR ROLLED STEEL JET PUMP KEYED			PREVIEW WDD 00	
CHECKED		FRAME 56C IP55 TEFC				
RELEASED						
REL. DATE		WMO	Jaragua do Sul	Product Engineering	SHEET	1 / 1

3 HP 02 Poles 60 Hz

A