

# DATA SHEET

## Three Phase Induction Motor - Squirrel Cage



Customer : V.J. PAMENSKY CANADA INC.

Product line : W01 - TEAO - Grain Dryer

Product code : 19011227

Frame	: 143/5TZ	Cooling method	: IC418 - TEAO
Insulation class	: F	Minimum air speed over motor	: 12.1 m/s
Duty cycle	: S1	Mounting	: F-3/B3T
Ambient temperature	: -20 °C to +40 °C	Rotation <sup>1</sup>	: Counter clockwise
Altitude	: 3280 ft	Starting method	: Direct On Line
Protection degree	: IP55	Approx. weight <sup>3</sup>	: 43.7 lb
Design	: B	Moment of inertia (J)	: 0.1471 sq.ft.lb

Output	3 HP (2.2 kW)	4.5 HP (3.3 kW)	
Poles	2	2	
Frequency	60 Hz	60 Hz	
Rated voltage	575 V	575 V	
Rated current	3.21 A	4.39 A	
L. R. Amperes	35.3 A	35.1 A	
LRC	11.0	8.0	
No load current	1.56 A	1.56 A	
Rated speed	3525 rpm	3485 rpm	
Slip	2.08 %	3.19 %	
Rated torque	4.41 ft.lb	6.69 ft.lb	
Locked rotor torque	410 %	270 %	
Pull up torque	345 %	230 %	
Breakdown torque	510 %	300 %	
Service factor	1.00	1.00	
Temperature rise	105 K	105 K	
Noise level <sup>2</sup>	68.0 dB(A)	68.0 dB(A)	
Locked rotor time (hot)	8 s	7 s	
Locked rotor time (cold)	14 s	13 s	
Efficiency (%)	50%	77.7	82.1
	75%	82.1	84.1
	100%	83.8	83.9
Power Factor	50%	0.63	0.76
	75%	0.76	0.86
	100%	0.83	0.90

Bearing type	Drive end	Non drive end	Foundation loads
	6205-ZZ	6203-ZZ	
Lubrication interval	-	-	Max. compression :
Lubricant amount	-	-	Load type :-
Lubricant type	MOBIL POLYREX EM		Load torque :-
			Load inertia (J=GD <sup>2</sup> /4) :-

Notes  
See notes on page 2.

This revision replaces and cancel the previous one, which must be eliminated.  
(1) Looking the motor from the shaft end.  
(2) Measured at 1m and with tolerance of +3dB(A).  
(3) Approximate weight, subject to be changed after manufacturing process.

These are average values based on tests with sinusoidal power supply, subject to the tolerances stipulated in NEMA MG 1-12.

Rev.	Changes Summary	Rev.	Checked	Date
Performed by	farazq			1847406541
Checked by	AUTOMATICO		Page	Rev.
Date	12/05/2026		1 / 2	0

# DATA SHEET

## Three Phase Induction Motor - Squirrel Cage



Customer : V.J. PAMENSKY CANADA INC.

Product line : W01 - TEAO - Grain Dryer

Product code : 19011227

**Thermal protection**

ID	Application	Type	Quantity	Sensing Temperature
1	Winding	Thermostat - 2 wires	1 x Phase	155°C

**Notes**

Standards	Specification : MG1 - Part 10	Vibration : MG1 - Part 7
	Test : MG1 - Part 12	Tolerance : MG1 - Part 12
	Noise : MG1 - Part 9	

This revision replaces and cancel the previous one, which must be eliminated.  
 (1) Looking the motor from the shaft end.  
 (2) Measured at 1m and with tolerance of +3dB(A).  
 (3) Approximate weight, subject to be changed after manufacturing process.

These are average values based on tests with sinusoidal power supply, subject to the tolerances stipulated in NEMA MG 1-12.

Rev.	Changes Summary	Rev.	Checked	Date
Performed by	farazq	1847406541		
Checked by	AUTOMATICO	Page	Rev.	
Date	12/05/2026	2 / 2	0	

A  
B  
C  
D  
E

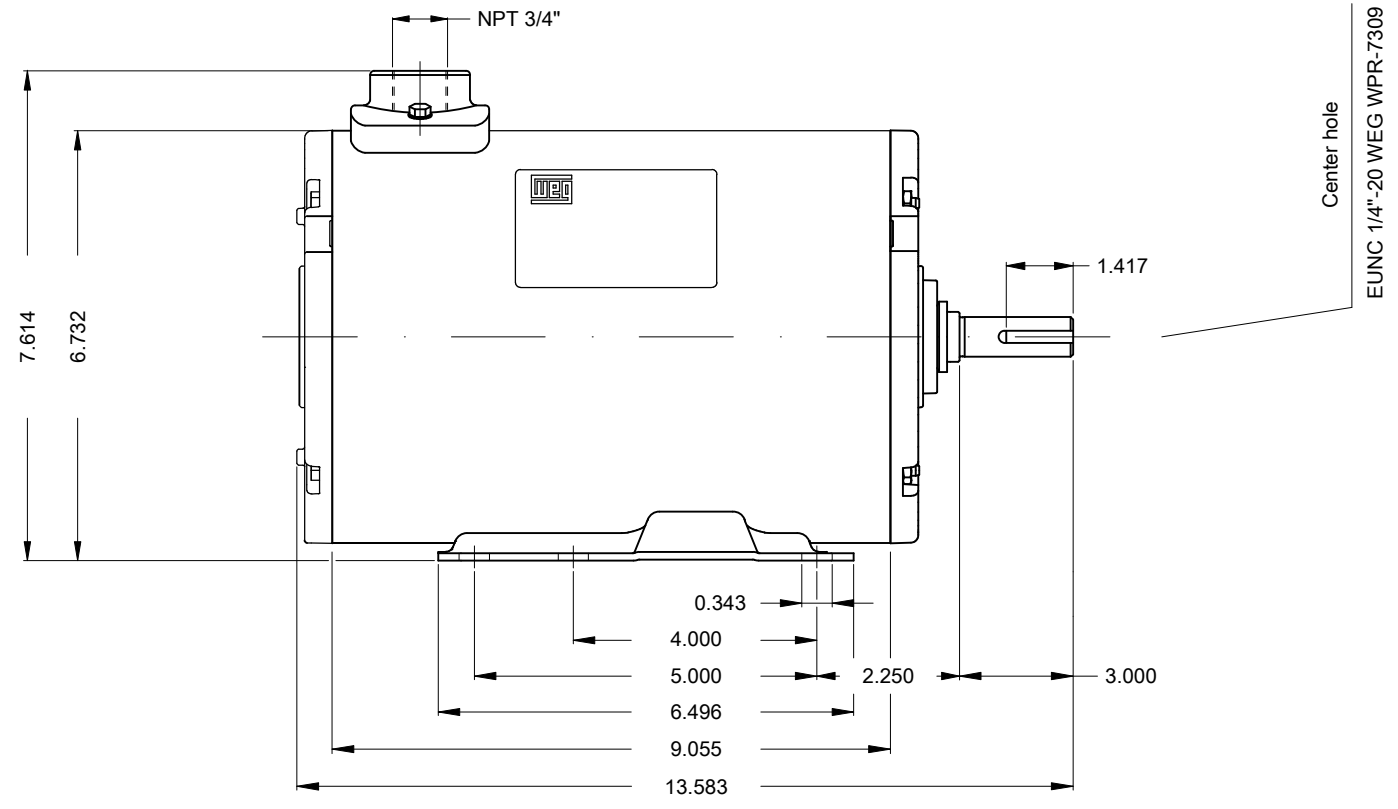
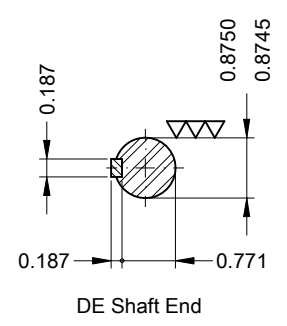
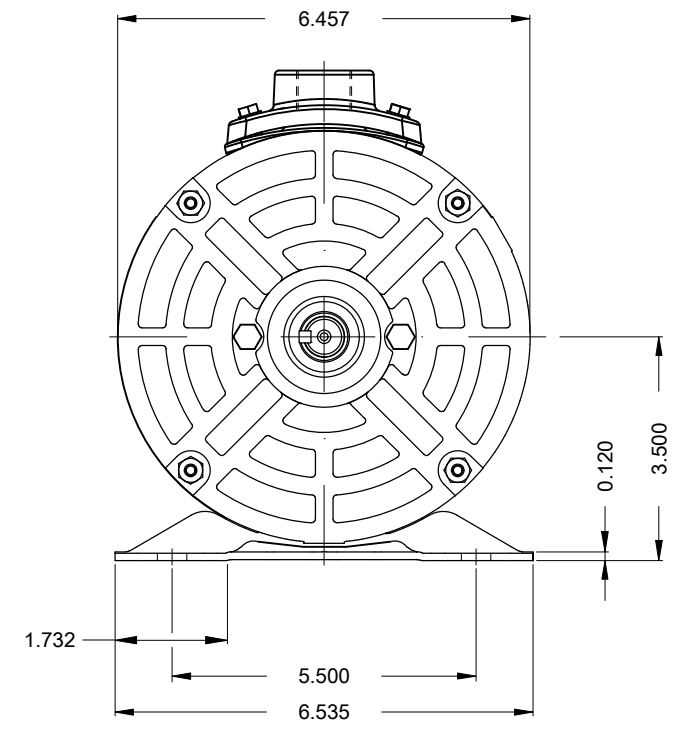
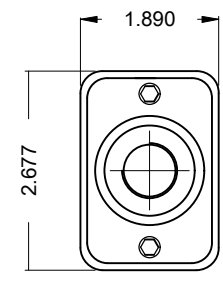

Reinforce the foot with 2 mig welding spots  
 Color RAL 7031  
 Painting plan 207N  
 Mounting MARKET F-3/B3T  
 Mounting B3T

						ALVAREZZ								00		
ECM	LOC	SUMMARY OF MODIFICATIONS				EXECUTED	CHECKED	RELEASED	DATE	VER						
EXECUTED	ALVAREZZ	THREE PH. MOTOR ROLLED STEEL GRAIN DRYER														
CHECKED		FRAME 143/5TZ IP55 TEAO														
RELEASED																
REL. DATE		WEG	HUEHUETOCA	[Ingenieria Motores Comerciales]	SHEET		1 / 1									

3.0-4.5 HP 02 Poles 60 Hz

A

