

# DATA SHEET

## Three Phase Induction Motor - Squirrel Cage



Customer	:			
Product line	: Standard Efficiency Three-Phase	Product code : 13522601		
Frame	: 56	Cooling method : IC01 - ODP		
Insulation class	: F	Mounting : F-1		
Duty cycle	: Cont.(S1)	Rotation <sup>1</sup> : Both (CW and CCW)		
Ambient temperature	: -20°C to +40°C	Starting method : Direct On Line		
Altitude	: 1000 m.a.s.l.	Approx. weight <sup>3</sup> : 10.1 kg		
Design	: A	Moment of inertia (J) : 0.0030 kgm <sup>2</sup>		
Output [HP]		1		
Poles		4		
Frequency [Hz]		60		
Rated voltage [V]		575		
Rated current [A]		1.44		
L. R. Amperes [A]		9.50		
LRC [A]		6.6x(Code L)		
No load current [A]		1.12		
Rated speed [RPM]		1750		
Slip [%]		2.78		
Rated torque [kgfm]		0.415		
Locked rotor torque [%]		250		
Breakdown torque [%]		290		
Service factor		1.15		
Temperature rise		80 K		
Locked rotor time		18s (cold) 10s (hot)		
Noise level <sup>2</sup>		52.0 dB(A)		
Efficiency (%)	25%			
	50%	68.0		
	75%	74.0		
	100%	77.0		
Power Factor	25%			
	50%	0.44		
	75%	0.58		
	100%	0.68		
Bearing type	: <u>Drive end</u> 6204 ZZ <u>Non drive end</u> 6202 ZZ	Foundation loads		
Sealing	: Without Without Bearing Seal Bearing Seal	Max. traction : 33 kgf Max. compression : 43 kgf		
Lubrication interval	: - -			
Lubricant amount	: - -			
Lubricant type	: Mobil Polyrex EM			
Notes				
This revision replaces and cancel the previous one, which must be eliminated. (1) Looking the motor from the shaft end. (2) Measured at 1m and with tolerance of +3dB(A). (3) Approximate weight subject to changes after manufacturing process. (4) At 100% of full load.		These are average values based on tests with sinusoidal power supply, subject to the tolerances stipulated in NEMA MG-1.		
Rev.	Changes Summary	Performed	Checked	Date
Performed by				
Checked by			Page	Revision
Date	17/05/2022		1 / 2	

# LOAD PERFORMANCE CURVE

Three Phase Induction Motor - Squirrel Cage



Customer :

Product line : Standard Efficiency Three-Phase Product code : 13522601

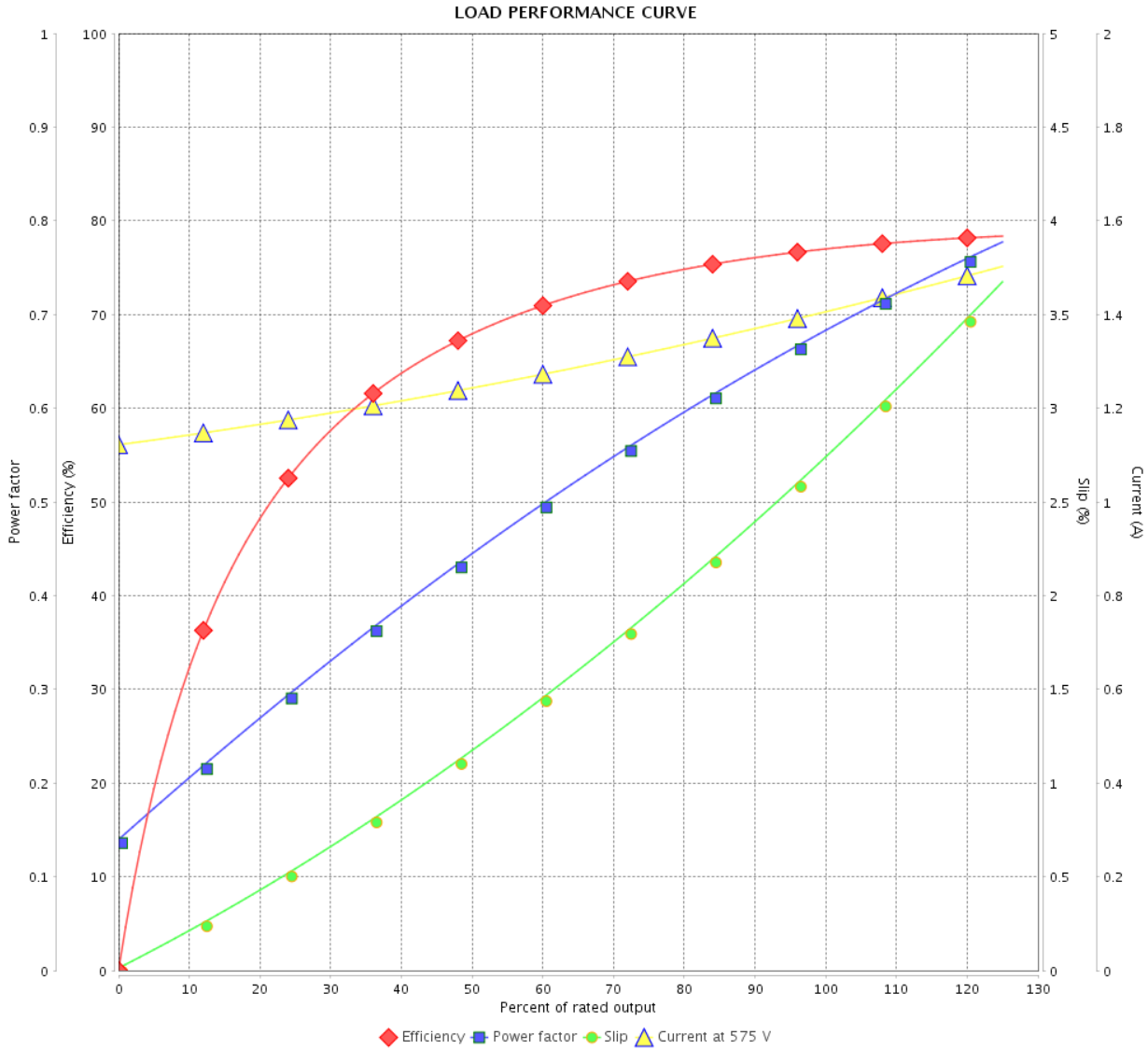

Performance : 575 V 60 Hz 4P

Rated current : 1.44 A  
 LRC : 6.6  
 Rated torque : 0.415 kgfm  
 Locked rotor torque : 250 %  
 Breakdown torque : 290 %  
 Rated speed : 1750 rpm

Moment of inertia (J) : 0.0030 kgm<sup>2</sup>  
 Duty cycle : Cont.(S1)  
 Insulation class : F  
 Service factor : 1.15  
 Temperature rise : 80 K  
 Design : A

Rev.	Changes Summary	Performed	Checked	Date
Performed by			Page 2 / 2	Revision
Checked by				
Date	17/05/2022			

1 2 3 4 5 6

A

B

C

D

E

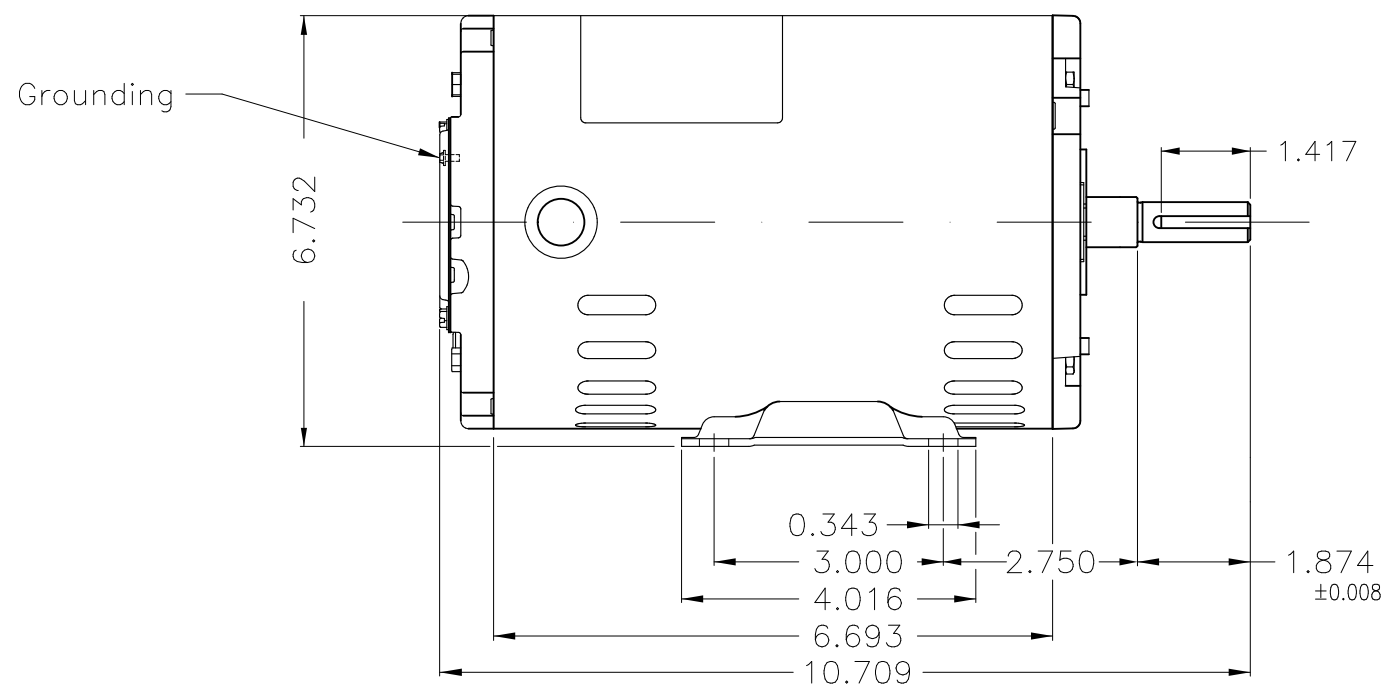
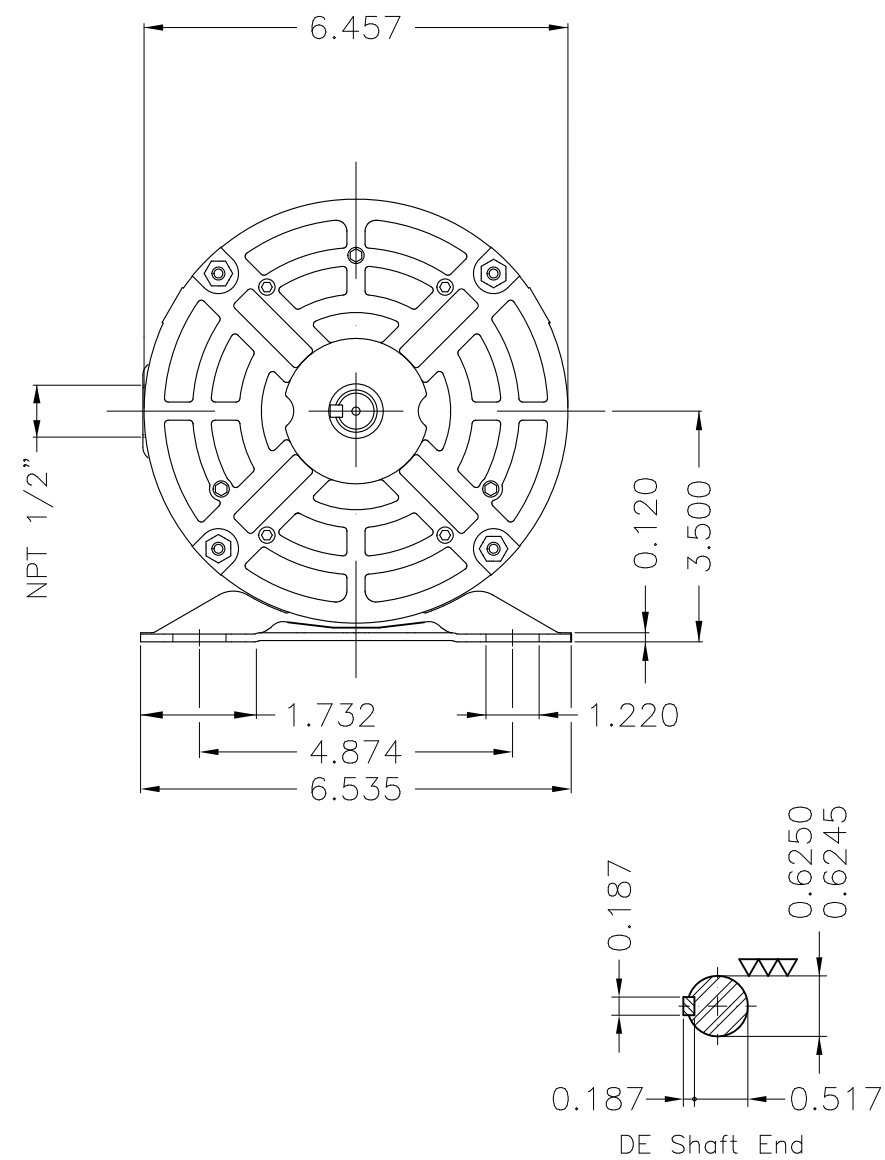

Color Munsell N 1 matte black							
Painting plan 207N							
Mounting F-1/B3R(D)							
				HYBRISUSER		00	
ECM	LOC	SUMMARY OF MODIFICATIONS		EXECUTED	CHECKED	RELEASED	DATE VER
EXECUTED	HYBRISUSER	THREE PH. MOTOR ROLLED STEEL		PREVIEW		WDD 00	
CHECKED		FRAME 56 IP21 ODP					
RELEASED							
REL. DATE		WMO	Jaragua do Sul	Product Engineering	SHEET	1 / 1	

1 HP 04 Poles 60 Hz

A