

DATA SHEET



Three Phase Induction Motor - Squirrel Cage

Customer :					
Product line		: ODP NEMA Premium Efficiency Three-Phase		Product code : 11003745	
Frame	:	284TC	Locked rotor time	: 27s (cold) 15s (hot)	
Output	:	25 HP (18.5 kW)	Temperature rise	: 80 K	
Frequency	:	60 Hz	Duty cycle	: Cont.(S1)	
Rated voltage	:	575 V	Ambient temperature	: -20°C to +40°C	
Poles	:	4	Altitude	: 1000 m.a.s.l.	
Rated current	:	23.9 A	Protection degree	: IP23	
	:	6.7x(Code H)	Cooling method	: IC01 - ODP	
Rated speed	:	1770 rpm	Mounting	: F-1	
Rated torque	:	10.3 kgfm	Rotation ¹	: Both (CW and CCW)	
Insulation class	:	F	Noise level ²	: 62.0 dB(A)	
Service factor	:	1.15	Starting method	: Direct On Line	
Moment of inertia (J)	:	0.1435 kgm ²	Approx. weight ³	: 163 kg	
Design	:	B			
Output	50%	75%	100%	Foundation loads	
Efficiency (%)	92.4	93.0	93.6	Max. traction : 329 kgf	
Power Factor	0.67	0.78	0.83	Max. compression : 492 kgf	
Bearing type	:	<u>Drive end</u> 6311 Z C3	<u>Non drive end</u> 6211 Z C3		
Sealing	:	Without Bearing Seal	Without Bearing Seal		
Lubrication interval	:	20000 h	20000 h		
Lubricant amount	:	18 g	11 g		
Lubricant type	:	Mobil Polyrex EM			
Notes					
This revision replaces and cancel the previous one, which must be eliminated. (1) Looking the motor from the shaft end. (2) Measured at 1m and with tolerance of +3dB(A). (3) Approximate weight subject to changes after manufacturing process. (4) At 100% of full load.			These are average values based on tests with sinusoidal power supply, subject to the tolerances stipulated in NEMA MG-1.		
Rev.	Changes Summary		Performed	Checked	Date
Performed by					
Checked by				Page	Revision
Date	14/04/2026			1 / 2	

LOAD PERFORMANCE CURVE

Three Phase Induction Motor - Squirrel Cage



Customer : _____

Product line : ODP NEMA Premium Efficiency Three-Phase Product code : 11003745

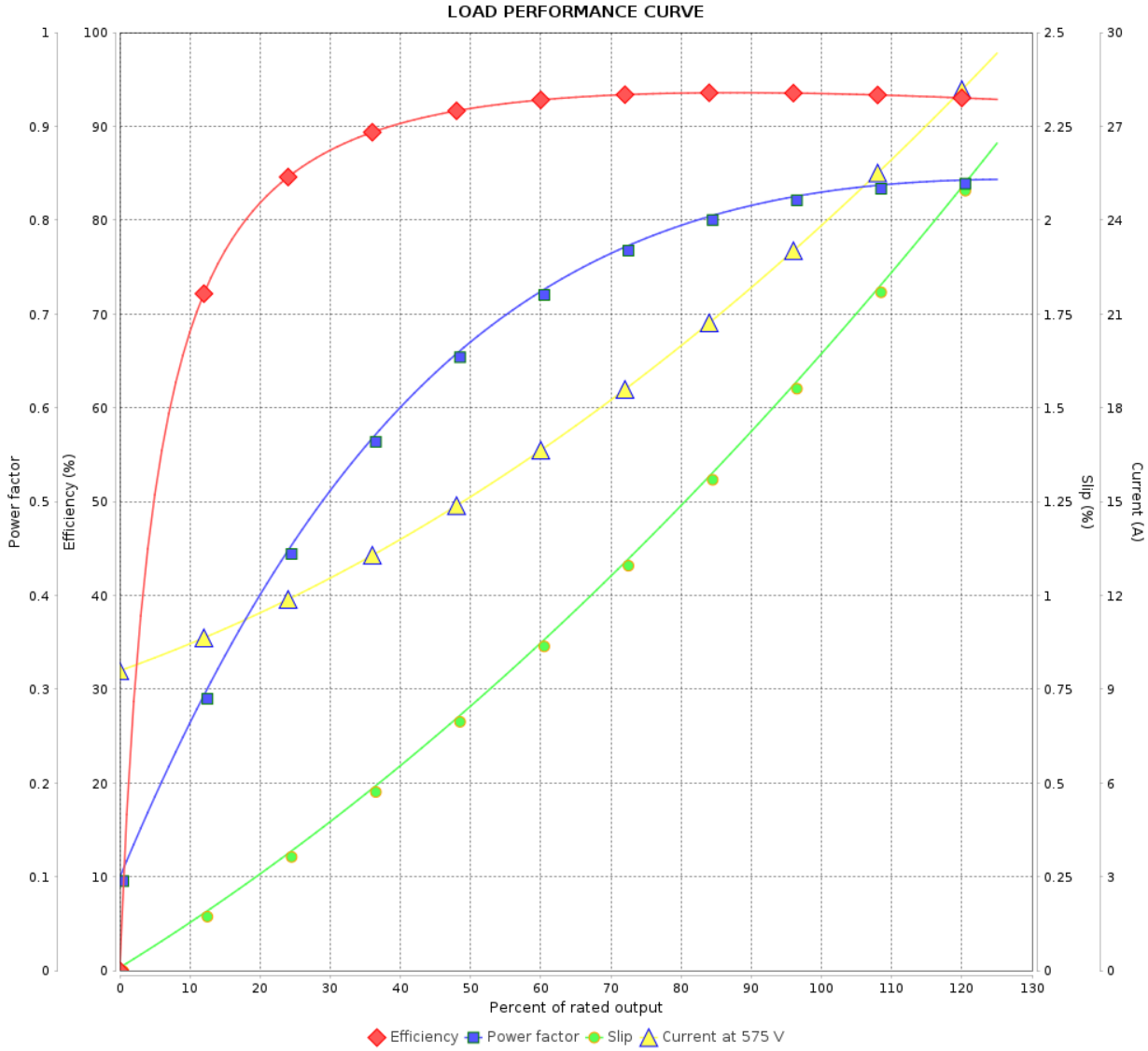

Rev.	Changes Summary	Performed	Checked	Date
Performed by		Page 2 / 2		Revision
Checked by				
Date				

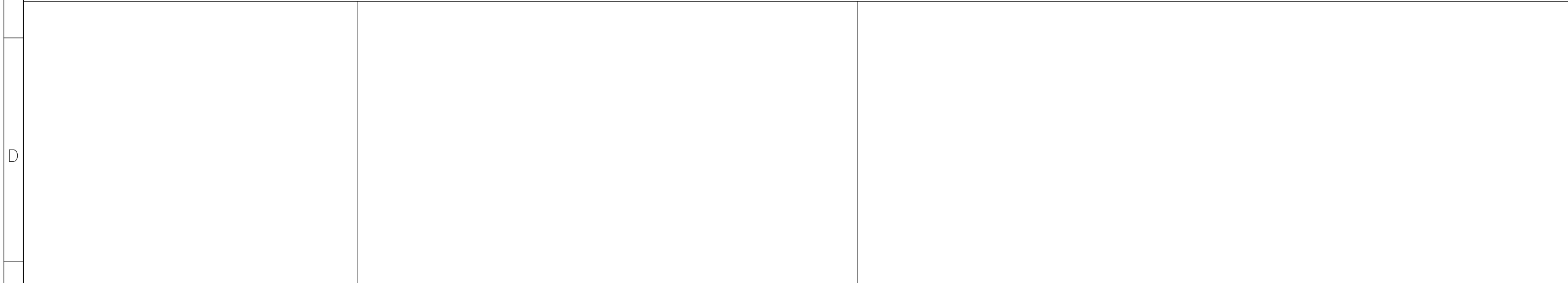
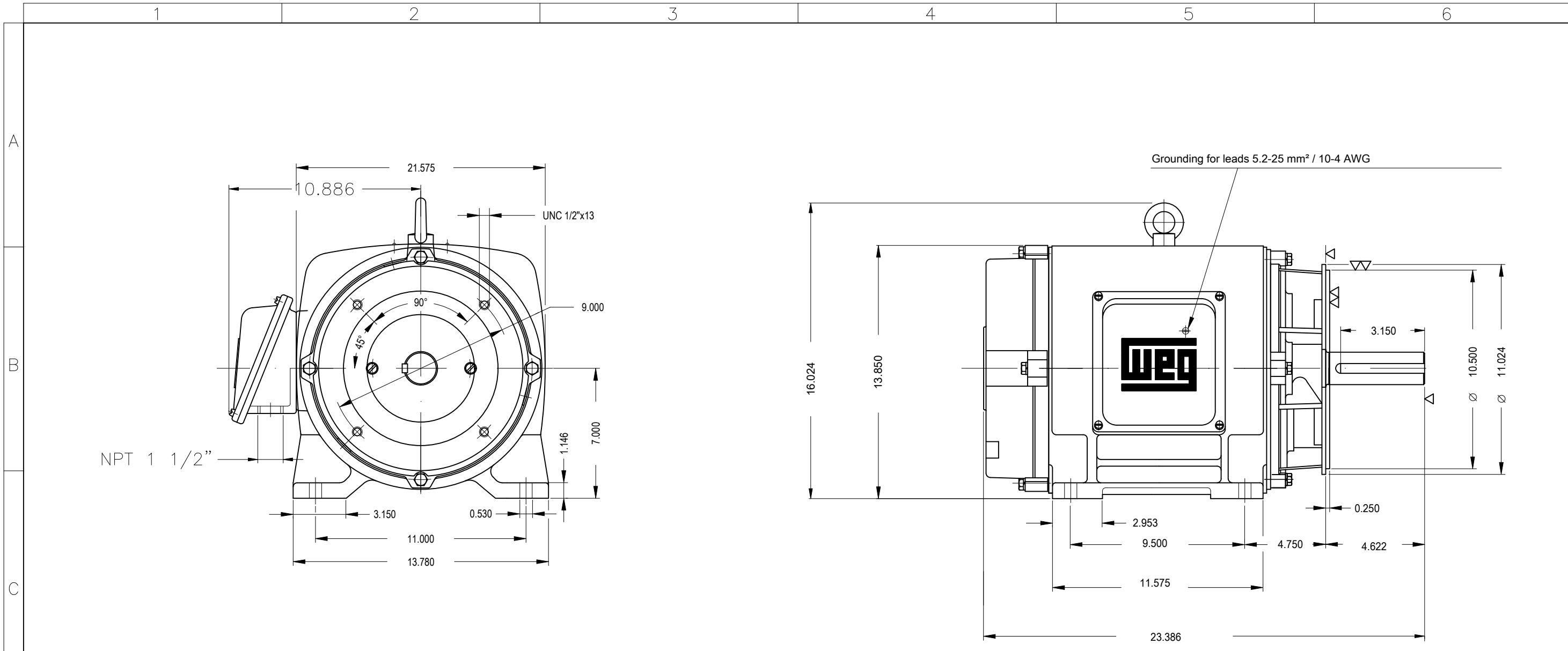

Color RAL 5009										25 HP 04 Poles 60 Hz										A
Painting plan 203A																				
Mounting B34D																				
										HYBRISUSER										00
EXECUTED										HYBRISUSER										
CHECKED										SUMMARY OF MODIFICATIONS										
RELEASED										THREE PH. MOTOR GENERAL NEMA PREM. EFF.										
REL. DATE										FRAME 284TC IP23 ODP										
										WMO Jaragua do Sul										Product Engineering
										EXECUTED										CHECKED
										RELEASED										DATE
										VER										
										PREVIEW										WDD 00
										SHEET 1 / 1										