

1 2 3 4 5 6

A

B

C

D

E

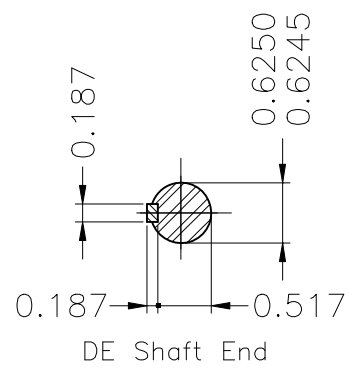
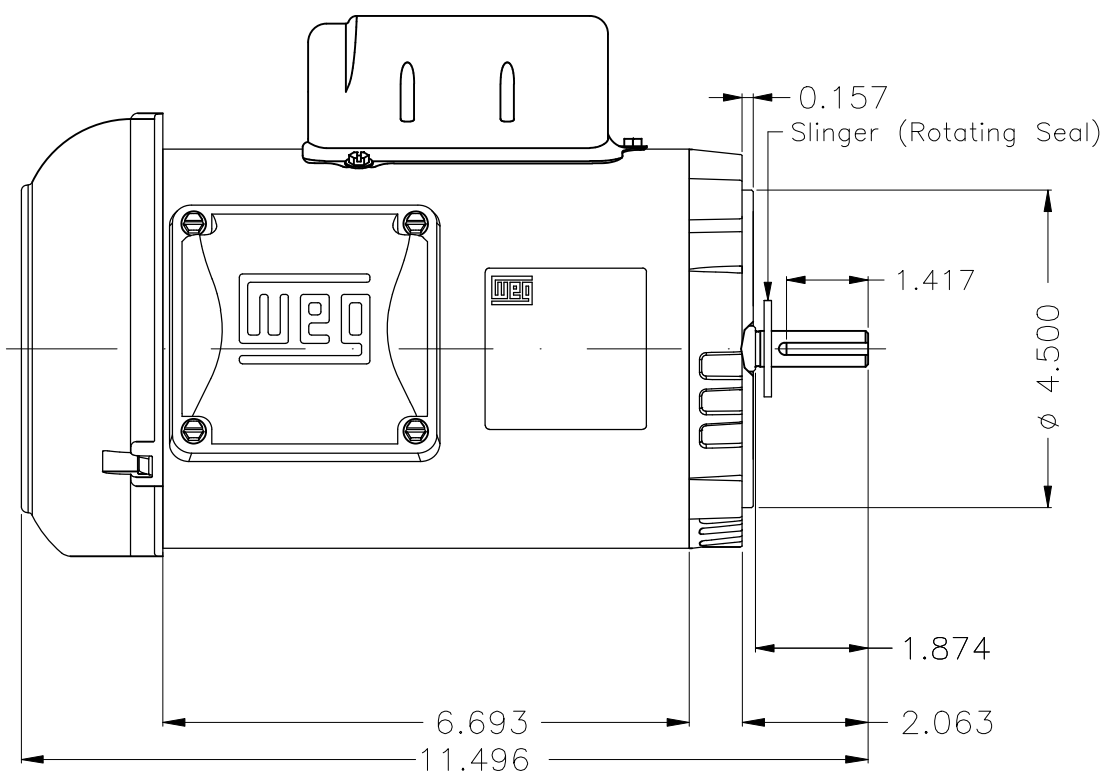
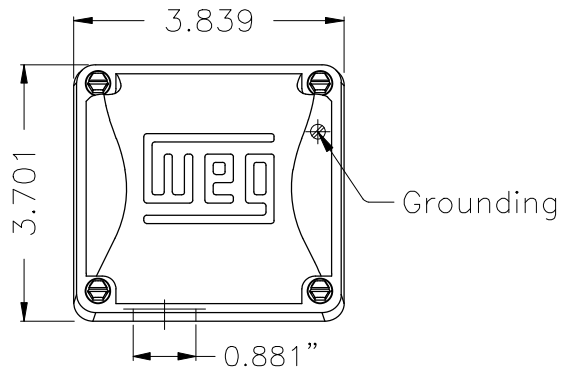
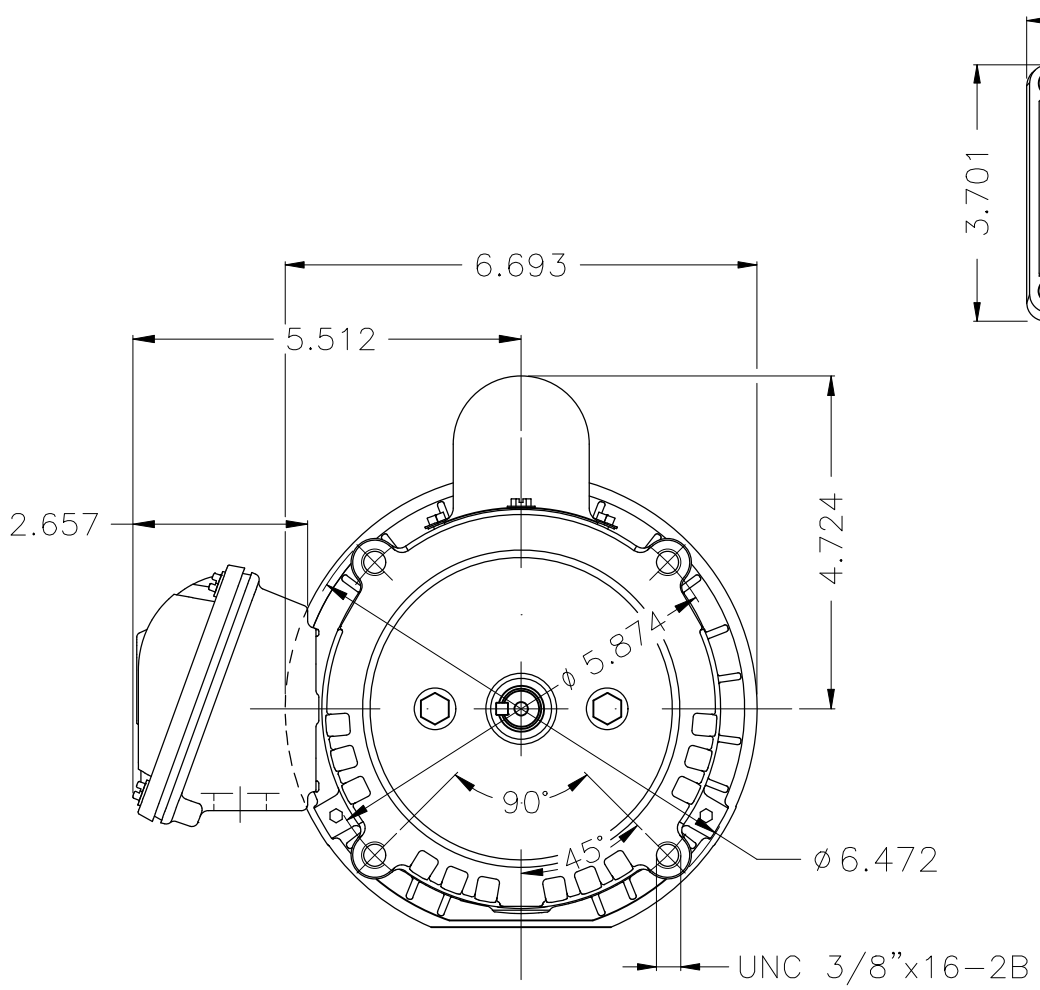

Dimensions in inches

Color Munsell N 1 matte black						
Painting plan 207N						
Mounting F-1/B14R(D)						
					HYBRISUSER	00
ECM	LOC	SUMMARY OF MODIFICATIONS		EXECUTED	CHECKED	RELEASED DATE VER
EXECUTED	HYBRISUSER	SINGLE PH. MOTOR ROLLED STEEL JET PUMP KEYED			PREVIEW	
CHECKED		FRAME W56C IP55 TEFC			WDD	00
RELEASED						
REL. DATE	WMO	Jaragua do Sul	Product Engineering	SHEET	1 / 1	

0.5 HP 02 Poles 60 Hz

A



XME A3