

No reproduction of this drawing is allowed without written permission of WEG Motores

EIXO	
PADRÃO	X
OPCIONAL	
ESPECIAL	

Dimensões em mm  
Dimensions in mm

THIS IS AN UPDATED REVISION, THE PREVIOUS ONE MUST BE DISREGARDED.

A

B

C

D

E

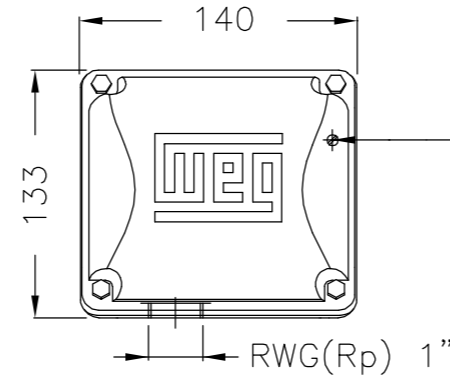
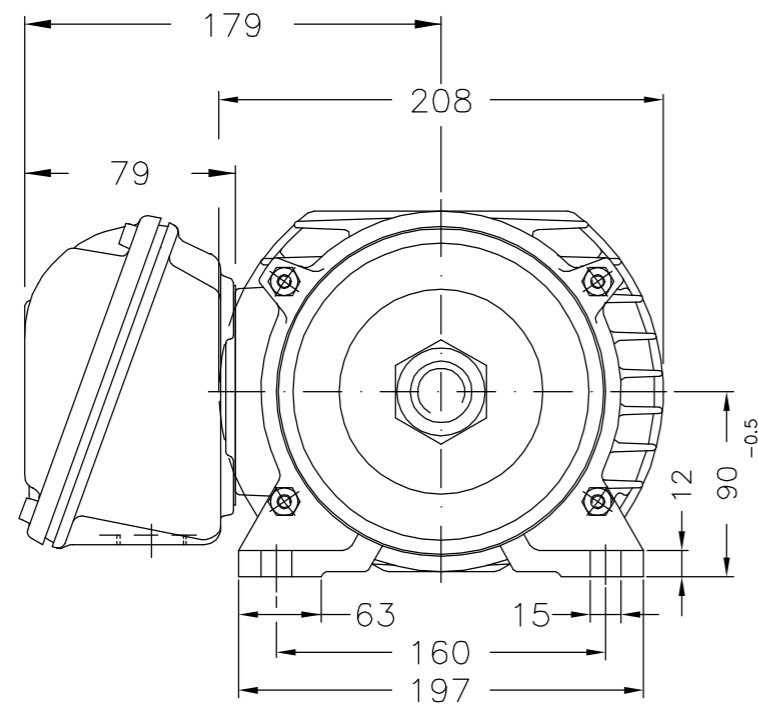

Main terminal box

Grounding for leads 2-10 mm<sup>2</sup> / 14-7 AWG

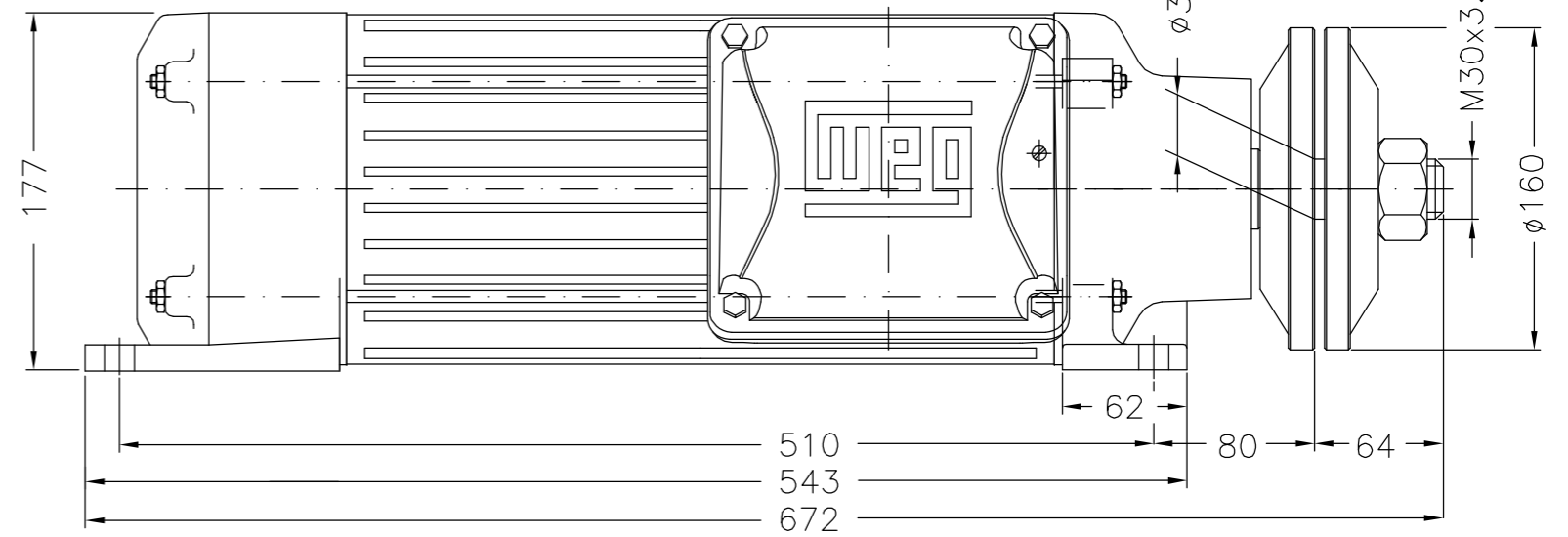

Fornecido com 2 arruelas onduladas no mancal traseiro /  
Supplied with 2 preload washers at non-drive end  
Isolamento Classe F (Dt=80K) / Class F insulation - 80K temperature rise  
Sentido de rotação anti-horário / Counter clockwise rotation  
Fator de serviço 1.0 / Service factor 1.0  
Forma construtiva B3D / Mounting B3R(D)

500001273522		ALT. CONFORME CLAIM 414559355	FRANCINES		CASSIO	23.02.2017	03		
500000656433		ALT. CONFORME CLAIM 412584631	ANDERSONLB		CAMILAH	11.09.2012	02		
ECM	LOC	SUMMARY OF MODIFICATIONS			EXECUTED	CHECKED	RELEASED	DATE	VER
EXECUTED	ADRIANAP	THREE PHASE SAW ARBOR MOTOR FRAME 90L/MS IP54			E1003239				
CHECKED					000	03			
RELEASED	RUDMAR				SHEET 1 / 1				
REL DT	21.09.2008	WMO	JARAGUA DO SUL	ENGENHARIA DE PRODUTO					

7.5 HP 4 POLE 60 Hz  
10 HP 2 POLE 60 Hz

B  
A